

PRODUCT SPECIFICATION

产品规格书

合盛弘能(宁波)科技有限公司

受控文件

Customer 客户名称 : _____
Product 产品名称 : _____ **锂离子电池** _____
Part No. 产品型号 : _____ **INR21700P4R2C4200** _____
Data 日期 : _____ **2024.08.20** _____
Version No. 版本号 : _____ **A7** _____

Designed 编制	Standardization 标准化	RD Checked 产品设计审核
		
Sales Checked 销售审核	QC Checked 品质审核	Approved 批准
		
Customer Approve 客户承认		

Amendment Records
文件修订履历

受控文件

Version 版本	Approval Date 批准日期	Change Section 变更部分	Description 变更内容	Remarks 备注
A0	2023.8.8	/	/	首次下发
A1	2023.8.18	主题	样版格式	
A2	2024.2.19	产品标识图例	增加电压容量、规格	
A3	2024.05.13	规格书编号 主题	编号由 HSHN-GY07-05-01-2023(A/2)变 更为 JSGF-07-007&A3 样版格式	
A4	2024.06.08	产品型号	1、由 LIB21700P4R2C4200 变更 为 INR21700P4R2C4200 2、电池打码规则与实物照片更新	
A5	2024.06.25	包装标签	包装标签与实物照片更新	
A6	2024.07.05	(1) 主要参数; (2) 产品结构、 尺寸; (3) 电芯出厂状 态。	(1) 删除直流内阻值及其测试方 法; (2) 产 品 尺 寸 变 更 为 21.65*70.5±0.2mm; (3) 调整电池荷电量与电压对应 值。	
A7	2024.08.20	包装方式	包装规格更新	

CONTENDS 目录

合盛弘能(宁波)科技有限公司

受控文件

1. Scope 适用范围	1
2. Description and Model 基本信息	1
2.1 Product 产品	1
2.2 Model(Type) 电芯型号	1
3. Parameters 主要参数	1
4. Product structure and size 产品结构、尺寸	3
5. Product identification 产品标识图例	3
6. Testing Methods 产品测试方法	3
6.1 Testing Conditions 测试条件	3
6.2 Test equipment 测试设备	3
6.3 Test for Capacitance 容量测试	4
6.4 Alternating Current Resistance(ACR) 交流内阻	5
6.5 Test for Low Temperature 低温性能测试	5
6.6 Rate discharge 倍率放电	6
7. Charging Method 充电方法	6
7.1 Standard Charge 标准充电	6
7.2 Rapid Charge 快速充电	6
8. Electrochemical Characteristics 电化学性能	7
9. Mechanical Properties 机械性能	9
10. Safety 安全性能	10
11. Satus of the Cell as of Ex-factory 电芯出厂状态	12
12. Instructions and precautions 使用指导和注意事项	12
12.1 Instructions 使用指导	12
12.2 Storage 储存	13
13. Shipment 运输	13
14. Warranty 质量保证	13
15. Packaging 包装信息	14
15.1 The packing label 包装标签	14
15.2 Packaging as shown below 包装按下图包装方式	14
15.3 Related information 相关信息	15
16. Needs of customers 客户需求	16
17. Consultation 技术咨询	16

1. Scope 适用范围

This product specification describes the performance, dimensions, characteristics, technical requirements, testing methods, and precautions of the INR21700P4R2C4200 lithium-ion battery product developed by Hesheng Hongneng (Ningbo) Technology Co., Ltd.

本产品规格书对合盛弘能（宁波）科技有限公司开发的 INR21700P4R2C4200 锂离子电池产品的性能、尺寸、特性、技术要求、测试方法及注意事项等进行了说明。

2. Description and Model 基本信息

2.1 Product 产品

Cylindrical ultra fast charging lithium-ion battery

圆柱型锂离子电池

2.2 Model(Type) 电芯型号

INR21700P4R2C4200

3. Parameters 主要参数

Item 项目	Specification 标准	Explain 备注
1 Capacitance 额定容量	4200mAh	@25±3°C
2 Minimum capacity 最低容量	4100mAh	@25±3°C
3 Nominal voltage 标称电压	3.6V	
4 Maximum working voltage 最大工作电压	4.2V	
5 Minimum operating voltage 最小工作电压	2.5V (T≥0°C) 2.0V (T<0°C)	

6	Alternating Current Resistance 交流内阻	≤5mΩ	(1kHz) 3.5±0.05V@25±3°C
7	Standard charge current 标准充电电流	2.1A(0.5C)	@25±3°C
8	Maximum charging current 最大充电电流	4.2A(1.0C)	@25±3°C
9	Rated current 额定放电电流	2.1A(0.5C)	@25±3°C
10	Max Continuous Discharge Current 最大持续放电电流	45A, 2.5V	T _{Recommended} : 75°C
			T _{Max} : 80°C
11	Operating environment temperature 工作温度范围	Charge 充电: 0~45°C Discharge 放电: -40~60°C	
12	Cell surface temperature* 电池表面温度*	Charge 充电: 0~45°C Discharge 放电: -40~80°C	
13	Storage Temperature Range (At Shipping SOC) 存储温度范围 (出货电压 SOC)	-20~45°C	-20~25°C, 1year
			-20~45°C, 3months
			-20~60°C, 1month
14	Standard Cycle Life 标准循环寿命 (0.5C 充 0.5C 放)	≥700 次	@25±3°C
15	Cell Weight 电池重量	≤70.0g	
16	Cell Dimensions 电池尺寸	Φ21.65×70.50 ±(0.2mm)	(直径×高度)

Note: The surface temperature of the battery refers to the temperature value at the highest position.

注: 工作温度是指单体外壳的最高温度。



4. Product structure and size 产品结构、尺寸

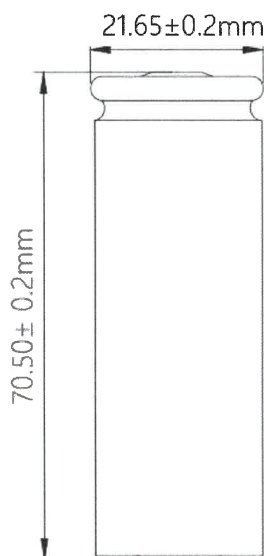

产品直径	产品高度
21.65±0.2mm	70.50±0.2mm
备注: 带套管状态	

5. Product identification 产品标识图例

+		INR 21700 42P	3.6V 4.2Ah 15.12Wh	-			
		BTCAP	C63J101300001				
+	INR	21700	42P	3.6V	4.2Ah	15.12Wh	-
正极	类型	型号	特性	电压	容量	电量	负极
BTCAP	公司名称			二维码内容: C63J101300001			

6. Testing Methods 产品测试方法

6.1 Testing Conditions 测试条件

The standard testing conditions of this product specification are: under standard atmospheric pressure, temperature 25±3°C, relative humidity less than 65%.

本产品规格书标准测试条件为: 标准大气压下, 温度 25±3°C, 相对湿度小于 65%。

6.2 Test equipment 测试设备

(1) Vernier Scale 游标卡尺

The slide caliper should have 0.01mm scale.

游标卡尺的测试精度应为 0.01mm。

(2) Ammeters and Voltmeters 电流表和电压表

The ammeters and voltmeters should have an accuracy of the grade 0.5mA and 0.5mV or higher.

电流表和电压表的精度应分别为 0.5mA 和 0.5mV 或以上。

(3) Impedance Meter 电压内阻测试仪

AC Impedance 1000 Hz

交流阻抗测量频率: 1000 Hz

(4) Other information 其他信息

- ❖ Temperature meter: Precision $\leq 0.5^{\circ}\text{C}$
温度仪表要求: 精度为 $\leq 0.5^{\circ}\text{C}$
- ❖ Time measurement tolerance: $\pm 0.1\%$
时间测试公差: $\pm 0.1\%$
- ❖ The size measurement tolerance; $\pm 0.1\%$
尺寸测量公差: $\pm 0.1\%$
- ❖ The quality measurement tolerance 0.1%
质量测量公差: $\pm 0.1\%$

合盛弘能(宁波)科技有限公司

受控文件

6.3 Test for Capacitance 容量测试

At $25\pm 3^{\circ}\text{C}$, discharge the battery with a constant current I to U_{\min} before testing. Charge the product at 2.1A(0.5C) to the set voltage of 4.2V, then charge it at constant voltage to 0.1A and cut off the current. Then, discharge the product at 2.1A(0.5C) to 2.5V. After standing for 30 seconds, repeat the above process again, and take the capacity value after the second discharge as the capacity value of the product.

在 $25\pm 3^{\circ}\text{C}$ 条件下, 在测试前, 先将电池用恒定电流 I 放电至 U_{\min} 。将产品以 2.1A(0.5C) 充电至设定电压 4.2V 后恒压充电至 0.1A 电流截止, 紧接着, 以 2.1A(0.5C) 电流将产品放电至 2.5V。静置 30s 后, 再次重复上述过程, 取第 2 次放电后的容量值为产品的容量值。

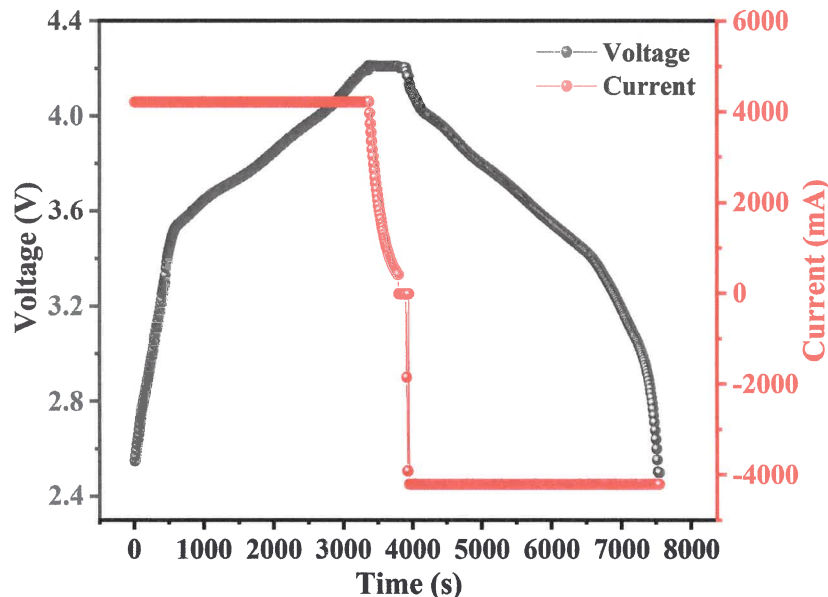

合盛弘能(宁波)科技有限公司
受控文件

6.4 Alternating Current Resistance(ACR) 交流内阻

Charge the cell to $3.5\pm 0.05V$ and keep this voltage for 30min, then using the AC Internal resistance to test its AC Resistance at 1kHz.

常温下，将单体充电至 $3.5\pm 0.05V$ 并恒压充电 30min 后，在 1kHz 条件下，采用交流阻抗仪进行交流内阻测试。

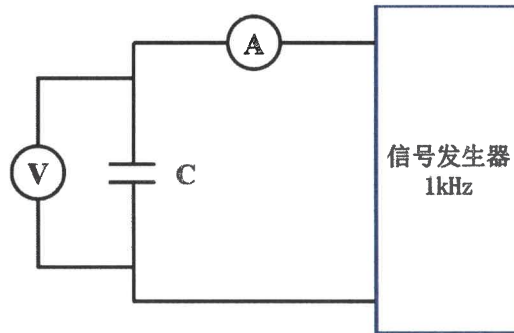

6.5 Test for Low Temperature 低温性能测试

Under the ordered temperature, constant charge the cell to 4.2V and then end it at 0.1A by constant voltage. After this, remove the cell to different temperature condition (keep 2h) and discharge it to 2.5V at 4.2A(1C) current, record its discharge capacitance.

在设定温度条件下，将单体充电至 4.2V 后恒压充电至 0.1A 截止，放入不同温度并保持 2h 后，以 4.2A(1C) 电流将单体放电至 2.5V，记录单体放电过程的容量。

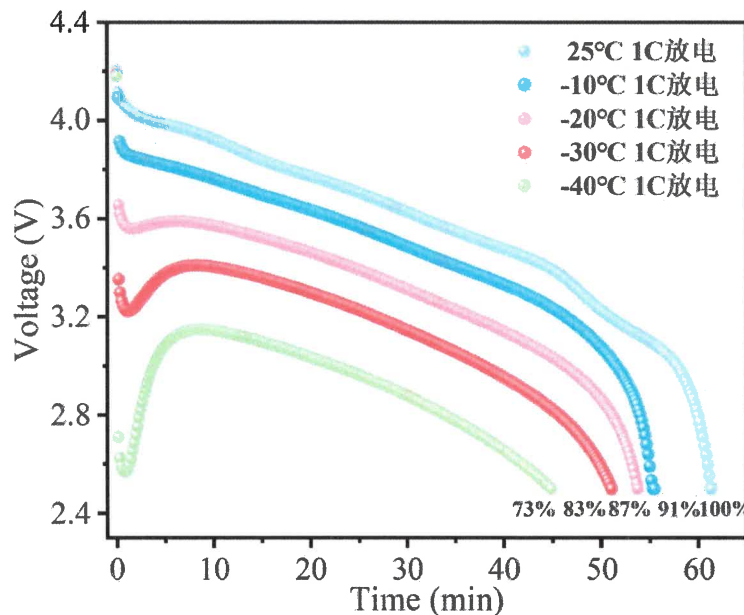

6.6 Rate discharge 倍率放电

Under $25\pm 3^{\circ}\text{C}$, test the cell's original performance by "Capacitance/resistance method", After charging according to the standard charging method, followed by constant current (N C) discharge to 2.5V at specified discharge rates at $25\pm 3^{\circ}\text{C}$.

在 $25\pm 3^{\circ}\text{C}$ 条件下, 按照“容量/内阻测试”方法测完初始性能后, 按标准充电方式充电后, 在 $25\pm 3^{\circ}\text{C}$ 下以给定放电倍率 N C 恒流放电至 2.5V。

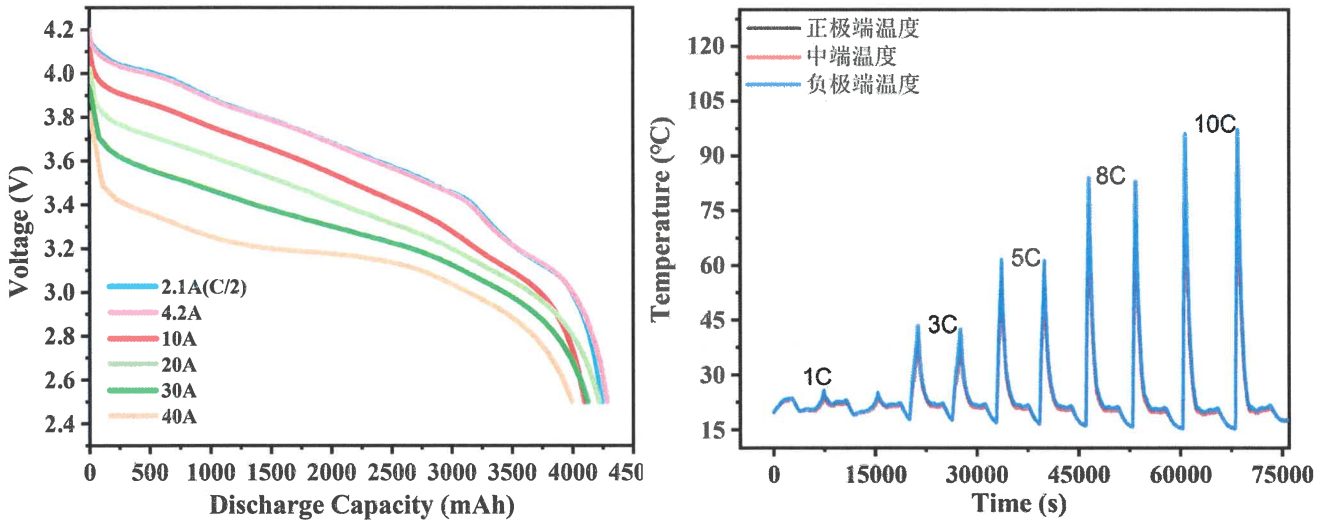

7. Charging Method 充电方法

7.1 Standard Charge 标准充电

Standard Charge refers to charging at a constant current of 2.1A (0.5C) to 4.2V at an ambient temperature of $25\pm 3^{\circ}\text{C}$, and then charging at a constant voltage until the current is less than 0.2A.

标准充电即在环境温度为 $25\pm 3^{\circ}\text{C}$ 的条件下, 先以恒定电流 2.1A(0.5C) 充电至 4.2V, 然后恒压充电至电流小于 0.1A。

7.2 Rapid Charge 快速充电

Rapid Charge refers to charging at a constant current of 4.2A (1C) to 4.2V at an ambient temperature of $25\pm 3^{\circ}\text{C}$, and then charging at a constant voltage until the current is less than 0.2A.

快速充电即在环境温度为 $25\pm 3^{\circ}\text{C}$ 的条件下, 先以恒定电流 4.2A(1C) 充电至 4.2V, 然后恒压充电至电流小于 0.1A。

合盛弘能(宁波)科技有限公司
受控文件

8. Electrochemical Characteristics 电化学性能

Item 项目		Test Condition 测试条件	Criteria 检验标准													
1	Standard discharge capacity 标准放电容量	At 25±3°C, fully charge the product with standard charging method, and then discharge it at 0.5C to a capacity of 2.50V. 在 25±3°C 条件下, 将产品以标准充电方式充满电, 然后以 2.1A(0.5C) 放电至 2.5V 截止的容量。	Standard discharge capacity ≥ 4100mAh 标准放电容量 ≥ 4100mAh													
2	Rate discharge performance* 倍率放电性能*	Standard charge followed by constant current(N C) discharge to 2.5V at specified discharge rates at 25±3°C. 按标准充电方式充电后, 在 25±3°C 下以给定放电倍率 N C 恒流放电至 2.5V。	<table border="1"> <thead> <tr> <th>Current (A)</th> <th>Relative Capacity (%)</th> </tr> </thead> <tbody> <tr> <td>2</td> <td>≥ 100</td> </tr> <tr> <td>10</td> <td>100</td> </tr> <tr> <td>20</td> <td>≥ 98</td> </tr> <tr> <td>30</td> <td>≥ 95</td> </tr> <tr> <td>40</td> <td>≥ 95</td> </tr> </tbody> </table>	Current (A)	Relative Capacity (%)	2	≥ 100	10	100	20	≥ 98	30	≥ 95	40	≥ 95	
Current (A)	Relative Capacity (%)															
2	≥ 100															
10	100															
20	≥ 98															
30	≥ 95															
40	≥ 95															
3	Standard cycle life 标准循环寿命	Under the condition of 25±3°C, the voltage is cyclically charged and discharged at 0.5C current between 4.2V~2.5V, and it is allowed to stand for 30min after each cycle. After completing 700 charge-discharge cycles, let stand for 1 hour, and then use standard charge-discharge to test the current capacity of the battery. 在 25±3°C 条件下, 以 0.5C 电流在 4.2V~2.5V 电压间循环充放电, 每次循环后静置 30min。完成充放电循环 700 次后, 静置 1h, 再使用标准充放电测试电池容量。	Capacity Retension $= \frac{\text{discharge capacity of 701th cycl}}{\text{original discharge capacity}}$ ≥ 80% 容量保持率 = $\frac{\text{第701次循环的放电容量}}{\text{初始放电容量}}$ ≥ 80%													

4	Discharge temperature performance test** 放电温度性能测试**	Under the condition of 25±3°C, fully charge the product with standard charging method, after rest more than 2h at the specified temperature, and then discharge it to 2.5V at a constant current of 4.2A(1C) within the same temperature. 25±3°C条件下, 将产品以标准充电方式充满电后, 在指定温度下静置 2h 并以 4.2A(1C) 恒流放电截至到 2.5V。	<div style="border: 2px solid red; padding: 5px; text-align: center; color: red; font-weight: bold;"> 合盛弘能(宁波)科技有限公司 受控文件 </div> -20°C: Capacity retention ≥ 85% -40°C: Capacity retention ≥ 70% 60°C: Capacity retention ≥ 100% -20°C: 容量保持率 ≥ 85% -40°C: 容量保持率 ≥ 70% 60°C: 容量保持率 ≥ 100%
5	25 °C storage performance 25 °C 存储性能	After charge at standard condition, and then stored at 25±3°C for 30 days. After this, discharge to 2.5V by standard condition. 标准充电方式充满电后 25±3°C 下存储 30 天, 以标准放电方式放电至 2.5V。	Capacity Retention $= \frac{\text{Residual capacity after 30 days storage}}{\text{original discharge capacity}} \geq 95\%$ 容量保持率 = $\frac{\text{存储30天剩余容量}}{\text{初始容量}} \geq 95\%$ Capacity recovery rate= $\frac{\text{Recover capacity after 30 days storage}}{\text{original discharge capacity}} \geq 98\%$ 容量恢复率 = $\frac{\text{存储30天恢复容量}}{\text{初始容量}} \geq 98\%$
6	High temperature storage performance 高温储存性能	Discharge the cell to 2.5V by 2.1A, and then charge (2.1A) the cell to 3.5V until the current cutoff is 0.1A at 25±3°C, and stored at 60°C for 30 days, and then rest at 25±3°C for 12 hours, after this, test the cell's capacity by standard charge/discharge condition. 在 25±3°C 下, 将电池放电至 2.5V 后以 2.1A 将其充电至 3.5V 并恒压充电至 0.1A 截止, 后将其转移至 60°C 环境下存储 30 天, 后在 25±3°C 下搁置 12h, 按照标准充放电方式复测电池的容量。	Capacity recovery rate $= \frac{\text{Recover capacity after 30 days storage}}{\text{original discharge capacity}} \geq 98\%$ 容量恢复率 = $\frac{\text{存储30天恢复容量}}{\text{初始容量}} \geq 98\%$

Note 注:

*The relative capacity value is divided the 3C discharge capacity at 25°C.

*容量保持率是基于 25°C环境温度下, 3C 放电容量值进行百分比计算所得。

**Capacity retention is calculated as a percentage of the 4.2A discharge capacity value based on a 25°C ambient temperature, with a set protection voltage of 2.0V.

**容量保持率是基于 25°C环境温度下, 4.2A 放电容量值进行百分比计算所得, 设置保护电压为 2.0V。

9. Mechanical Properties 机械性能

Test Item 测试项目		Test Method 测试方法	Criteria 检验标准
1	Drop Test 跌落测试	<p>Under normal temperature conditions, fully charge the battery to 4.2V, and drop the battery cell from a height of 1.5m in the direction of positive and negative poles to the cement floor. After the experiment, place it for at least 1 hour and conduct a visual inspection.</p> <p>常温条件下, 将电池充满电至 4.2V 状态, 电芯从 1.0m 的高度以正负极柱的方向跌落至水泥地面, 实验后放置至少 1h 后进行外观检查。</p>	<p>No explosion, no fire 不爆炸、不起火</p>
2	Vibration Test 振动测试	<p>At room temperature, fix the fully charged battery cell with standard charging method on the vibration table, increase the vibration frequency from 7Hz to 200Hz within 15 minutes, and then reduce it to 7Hz. Repeat the above steps for 3 hours. Maintain an acceleration of 1g during the process of increasing from 7Hz to 18Hz, and maintain an acceleration of 8g during the process of increasing from 18Hz to 200Hz.</p> <p>在室温条件下, 将以标准充电方式充满电的电芯固定在振动台上, 在 15min 内将振动频率由 7Hz 增加到 200Hz 后再降低至 7Hz, 重复上述步骤实验 3h。7Hz 增加到 18Hz 的过程中保持 1g 的加速度, 18Hz 增加到 200Hz 的过程中保持 8g 的加速度。</p>	<p>No explosion, no fire, no leakage, Voltage drop less than 5% 不爆炸、不起火、不漏液、电压下降小于 5%</p>

合盛弘能(宁波)科技有限公司

受控文件

10.Safety 安全性能

Test Item 测试项目	Test Method 测试方法	Criteria 检验标准
1 Hot Test 高温测试	<p>The standard rechargeable battery (4.2V) is heated to $130\pm 2^{\circ}\text{C}$ at a heating rate of $5^{\circ}\text{C}/\text{min}$ and heated in the oven for 10 minutes.</p> <p>标准可充电电池 (4.2V) 以每分钟 $5\pm 2^{\circ}\text{C}$ 的加热速率加热到 $130\pm 2^{\circ}\text{C}$, 并在 $130\pm 2^{\circ}\text{C}$ 下保持 10min。</p>	No explosion, no fire 不爆炸、不起火
2 Sea Water Immersion Test 海水浸泡	<p>The cell was immersed in 3.5%NaCl solution (mass fraction, simulated seawater composition at normal temperature) for 2h.</p> <p>将电芯完全浸入 3.5% NaCl 溶液 (质量分数, 模拟常温下的海水成分) 中搁置 2h。</p>	No explosion, no fire 不爆炸、不起火
3 Over-discharge Test 过放电	<p>Constant discharge with 1C current for 90min , then observed for 1h.</p> <p>以 1C 电流恒流放电 90min, 观察 1h。</p>	No explosion, no fire, no leakage 不爆炸、不起火、不漏液
4 Overcharge Test 过充电	<p>Batteries fully discharged by the standard discharge process are charged to 4.6V at 13.2A constant current, charged at 4.6V constant voltage, and the test is ended when the surface temperature drop value of the battery reaches 20% of the maximum temperature or the total charging time reaches 7h.</p> <p>标准放电流程完全放电的电池, 以 13.2A 恒流充电至 4.6V, 在 4.6V 恒压充电, 当电池表面温度下降值达到最高温度的 20%或者总充电时间达到 7h, 结束测试。</p>	No explosion, no fire 不爆炸、不起火

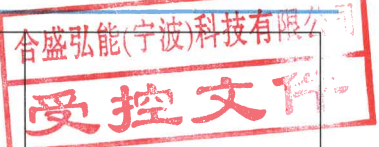

5	Short-circuit Test 短路测试	Short the positive and negative terminals of the battery, the total resistance of the external line $80 \pm 20\text{m}\Omega$, when the battery voltage $<0.2\text{V}$ and the surface temperature of the battery is restored to within 10°C difference from the ambient temperature, end the experiment. 短接电池的正负极, 外部线路总电阻 $80\pm 20\text{m}\Omega$, 当电池电压 $<0.2\text{V}$ 且电池表面温度恢复到与环境温度相差 10°C 以内, 结束实验。	No explosion, no fire 不爆炸、不起火
6	Thermal Shock Test 热冲击测试	After fully charged according to the standard charge method, the cell is put in an oven. Then set the oven temperature as follows: (1) Decrease the oven temperature from chamber temperature to -40°C within 60 min and keep the cell under -40°C for 90 min; (2) Raise the oven temperature from -40°C to 25°C within 60min; (3) Raise the oven temperature from 25°C to 85°C within 90 min and keep the cell under 85°C for 110 min; (4) Decrease the oven temperature from 85°C to 25°C within 70 min; (5) Repeat the sequence for a further 4 cycles. Afterwards, the cell is observed for 1h. 电芯按标准充电方式充电后放入温度箱中, 然后按以下步骤调节温度箱的温度: (1)在60min内由 25°C 降温至 -40°C , 保持90min; (2)在60min内温度由 -40°C 升至 25°C ; (3)在90min内温度由 25°C 升至 85°C , 保持110min; (4)在70min内温度由 85°C 降至 25°C ; (5)循环上述步骤4次。结束后观察1h。	No explosion, no fire 不爆炸、不起火

7	Low Pressure Test 低气压测试	After charging according to the standard charging method, the battery cell is stored for 6 hours at 25±3°C and an absolute pressure of 11.6kPa. Low-pressure area test shall be carried out according to UN38.3 standard. 电芯按标准充电方式充电后, 在 25±3°C、绝对压力为 11.6kPa 条件下存储 6h。低气压测试按照 UN38.3 标准执行。	No explosion, no fire, no leakage 不爆炸、不起火、不漏液
8	Forced Discharge Test 强制放电测试	A discharged cell is subjected to a reverse charge at 4.2A (1C) for 90 min. 放电后的电池以 4.2A (1C) 的电流反向充电 90min。	No explosion, no fire 不爆炸、不起火

11. Status of the Cell as of Ex-factory 电芯出厂状态

The battery cell should ensure transportation within the range of 3.30V to 3.60V (20-45% SOC).

电芯应保证在 3.30V 至 3.60V(20~45%SOC)范围内转运。

12. Instructions and precautions 使用指导和注意事项

12.1 Instructions 使用指导

- ❖ The operating temperature of lithium-ion batteries should not exceed the upper or lower limit of rated temperature.
锂离子电池的使用温度不宜超过额定温度上限或下限。
- ❖ Lithium-ion batteries should be used within the rated voltage range.
锂离子电池应在额定电压区间下使用。
- ❖ Please confirm the polarity of the lithium-ion battery before use, and reverse connection is prohibited.
锂离子电池在使用之前请确认极性, 禁止反接。
- ❖ The external environmental temperature has a significant impact on the lifespan of lithium-ion batteries. Please stay away from heat sources.
外界环境温度对锂离子电池的寿命具有重要影响, 请远离热源。

- ❖ Do not come into direct contact with water, oil, acid, or alkali for lithium-ion batteries.
锂离子电池请勿直接接触水、油、酸或碱。
- ❖ Do not squeeze, nail or disassemble lithium-ion batteries.
请勿挤压、钉刺或拆解锂离子电池。
- ❖ Although the cell contains no environmentally hazardous component, such as lead or cadmium, the battery shall be disposed according to the local regulations when it is disposed.
虽然电池不含有害环境的成分，如铅或镉，但电池在处理时应按当地规定进行处理。
- ❖ This product has a certain voltage value before shipment. Do not short-circuit the positive and negative terminals during use.
本产品发货前已具有一定电压值，使用过程切勿使正负极端短路。



12.2 Storage 储存

- ❖ Lithium ion batteries should not be placed in places with a relative humidity of over 85% or containing toxic gases. In such environments, the leads and casing are prone to moisture and corrosion, leading to circuit breakers in lithium-ion batteries.
锂离子电池不可处于相对湿度为 85%以上或含有有毒气体的场所，该种环境下引线及壳体易受潮及腐蚀，导致锂离子电池断路。
- ❖ If batteries need to be stored for a long time, please store them in a well ventilated area with a temperature of $25\pm 3^{\circ}\text{C}$, a relative humidity of below 60%, a voltage not exceeding 3.50V, and no exposure to sunlight.
电池若需长期储存，请在温度 $25\pm 3^{\circ}\text{C}$ ，相对湿度 60%以下，电压不超过 3.50V，通风良好的场所存放，严禁暴晒。

13. Shipment 运输

- ❖ The capacity of delivery cell is approximately at 20~ 45% of charging. It is not specified more than 45% capacity remain at customer, because of self-discharge. During transportation, keep the cell from acutely vibration, impacting, solarization, drenching.
出货电芯处于 20~45%电量状态，由于电芯存在自耗，运送到客户端的电芯无法完全保证 45%荷电量。运输过程应防止剧烈振动、冲击、日晒雨淋。

14. Warranty 质量保证

- ❖ From the date of shipment, the shelf life of the battery cells is determined by the contract. However, during this period, if there are quality issues with the battery cells caused by

customer misuse rather than the manufacturing process of Hesheng Hongneng (Ningbo) Technology Co., Ltd, Hesheng Hongneng (Ningbo) Technology Co., Ltd does not promise to replace them for free.

自出货之日起, 电芯的保质期限依合同而定。但是, 在此期限内, 如果非合盛弘能(宁波)科技有限公司的制程原因而是客户的误用造成的电芯质量问题, 合盛弘能(宁波)科技有限公司不承诺免费更换。

- ❖ Hesheng Hongneng (Ningbo) Technology Co., Ltd assumes no responsibility for any issues arising from violating safety regulations during operations.

合盛弘能(宁波)科技有限公司对违反安全守则操作所产生的问题不承担任何责任。

15. Packaging 包装信息

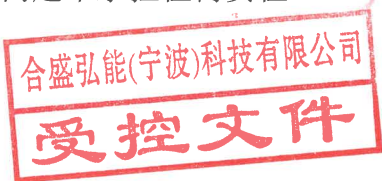

15.1 The packing label 包装标签

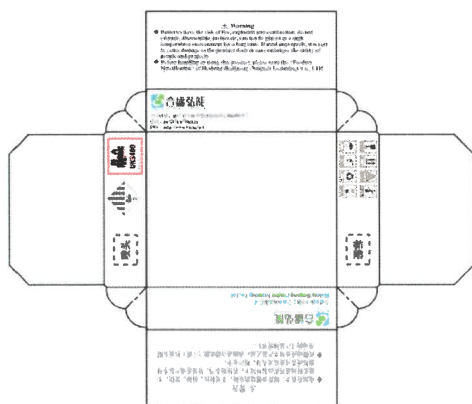

 合盛弘能 合盛弘能(宁波)科技有限公司 Hesheng Hongneng (Ningbo) Technology Co., Ltd	
客户名称	标准容量 (mAh)
产品型号	出货内阻 (mΩ)
数量 (pcs)	出货电压 (V)
等级	出库日期
订单号	箱号
备注	

15.2 Packaging as shown below 包装按下图包装方式

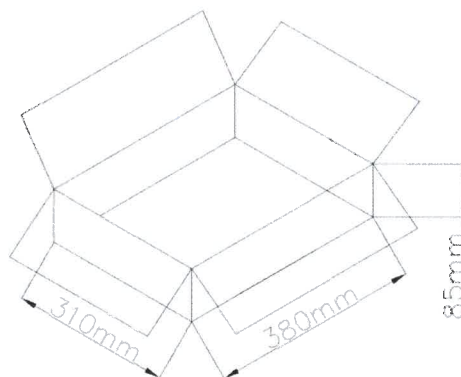
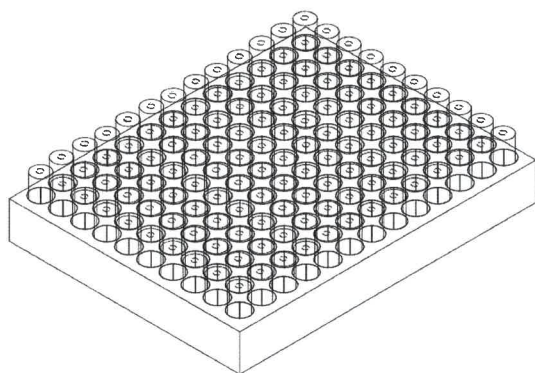

Series 型号系列	Numbers 数量(个)	Size 尺寸(W×L×H, mm)	Mass 重量(kg)
INR21700P4R2C4200	1	380×310×85mm	≤10

合盛弘能(宁波)科技有限公司
 受控文件

15.3 Related information 相关信息

Series 序号	Part Name 部件名称	Materials 材料	Q'Ty 单位
1	battery 电池	Corresponding battery model 对应电池型号	130pcs/box
2	Battery Data Sheet 电池数据单	A4 paper A4 纸	1pcs/box
3	Finished Product Inspection Form 成品检验单	A4 paper A4 纸	1pcs/box
4	Liner Panel 内衬板	Blister box 吸塑盒	2pcs/box
5	Carton 纸箱	double pit corrugated paper 单/双坑瓦楞纸	2pcs/box
6	Outer box label 外箱标签	Adhesive label 不干胶标签	1pcs/box
7	Adhesive tape 胶带	Polyethylene 聚乙烯	0.01 rol/box

16. Needs of customers 客户需求

If the content described in this document cannot meet your company's needs, please fill out the information in the table below and contact Hesheng Hongneng (Ningbo) Technology Co., Ltd.

若该文件所描述的内容无法满足贵司的需求, 请填写下表信息, 并与合盛弘能(宁波)科技有限公司联系。

Hesheng Hongneng (Ningbo) Technology Co., Ltd. will implement your company's needs and provide high-quality services to your company.

合盛弘能(宁波)科技有限公司将贯彻落实贵司的需求, 向贵司提供优质服务。

Series 序号	Existing information 已有信息	Demand Information 需求信息	Existing standards 已有标准	Demand criteria 需求标准

Company Name 公司名称: _____

Sign 签名及联系方式: _____

Date 日期: _____

17. Consultation 技术咨询

If you have any questions about lithium-ion batteries, please consult as follows:

Address: 1999-9 Zhouxi Road, Zhouxiang Town, Cixi City, Zhejiang Province

Tel No.: 86-0574-87906826

Fax No.: 86-0574-87906826

Website: <http://www.btcap.net>

如有任何关于锂离子电池的问题, 请按以下方式咨询:

厂址: 浙江省慈溪市周巷镇周西公路 1999-9 号

电话: 86-0574-87906826

传真: 86-0574-87906826

网址: <http://www.btcap.net>



Enterprise official account

企业公众号

