

Customer's Name/客户名称:

File No./文件编码: ATLWP-0268

Version/版本: A.0

Date/日期: 2024/7/22



广东小电新能源有限公司

Guangdong Micro Power New Energy CO., Ltd

Model/型号: 21700--5000mAh

Specifications/规格: 3.85V/ 5000mAh

Prepared by/Date 制定/日期	Checked by/Date 审核/日期	Approved by/Date 批准/日期
邹学其	郑小聪	
Customer Approved 客户确认		

(注: 确认无误后, 请在封面及第 12 页签字, 整套回传.)

地址: 广东省惠州惠阳区镇隆星和实业4栋

Amendment Records/修改记录

Version/版本	Date/日期	Description/描述
A/0	2024年7月22日	新版发行

Guangdong Micro Power New Energy CO., Ltd

Specifications for 21700-5000mAh

1 Scope 适用范围

This specification is applied to ATLWP polymer lithium ion cell manufactured by Guangdong Micro Power New Energy CO., Ltd

本产品规格书适用于广东小电新能源有限公司生产的聚合物锂离子电芯。

2 Product and Model Name 产品种类及型号

2.1 Product: Polymer Lithium Ion Cell

产品种类: 聚合物锂离子电芯

2.2 Model Name: WP-21700-5000

产品型号: WP-21700-5000

Ratings 主要技术参数

Item/项目		Criteria/标准	Remark/备注
3.1 Capacity 容量	Typical 典型	5050mAh	Discharge 0.2C cut off Voltage 2.75V for cell 0.2C 放电至 2.75V 截止
	Minimum 最小	5000mAh	
3.2 Nominal Voltage 标称电压		Average 3.85V	Discharge:0.2CmA(1000mA) cut off Voltage:2.75V for cell 0.2CmA 放电至 2.75V 截止
3.3 AC Impedance Resistance 内阻		≤60mΩ	
3.4 Discharge Cut-off Voltage 放电截止电压		2.75V	
3.5 Charge Current 充电电流		5000mA	1.0C
3.6 Charge Voltage 充电电压		4.4V	
3.7 Max. Charge Voltage 充电最高电压		4.4V	
3.8 Max. Charge Current 最大充电电流		5000mA(1C)	
3.9 Charging Current (C.C) 放电电流 (恒流放电)		5000mA(5A)	Standard Charging 标准放电
		10000mA(2C)	Max.Charging Current 最大放电电流
3.10 Operating Temperature 工作温度	Charge 充电	10~45℃	
	Discharge 放电	0~60℃	
3.11 Storage Temperature 储存温度	less than 1 month 小于一个月	-20~+45℃	Recommended storage temperature: 20℃,at the shipment state 运输时推荐贮存温度为 25±2℃
	less than 6 months 小于六个月	-20~+35℃	

3 Outline Dimensions and Appearance 电芯外形尺寸及外观

3.1 Outline Dimensions 外形尺寸

See attached drawing for WP-21700(Fig.1).

外形尺寸参见“WP--21700 外形尺寸图”（图 1）。Diameter: 21.5mm max. (Measured with weighting 300gf at 25±2℃) Length: 71.00mm max.

直径: 21.5mm max. (测量时测量仪器作用于电池上的压力为 300gf, 温度 25±2℃)

长度: 71.00mm max.

This diameter will be swelling when high temperature storage or operation in high temperature.

备注: 电芯在高温下贮存或使用直径会发生少许膨胀。

3.2 Appearance 外观

There shall be no such defect as scratch, flaw, crack, rust, leakage, which may adversely affect commercial value of cell.

电芯外表面清洁, 无电解液泄漏, 无明显的划痕及机械损伤, 无变形, 无影响电芯价值的其它外观缺陷。

4 Performance 性能

4.1 Standard Test Conditions 标准测试条件

Test should be conducted with new cells within one month after shipment from our factory and the cells shall not be cycled more than five times before the test. Unless otherwise defined, test and measurement shall be done under temperature of 25±2℃ and relative humidity of 45~85%. The test results are not affected evidently by such conditions of temperature 25~35℃ or humidity 25~85%RH.

测试电芯必须是本公司出厂时间不超过一个月的电芯, 且电芯未进行过五次以上充放电循环。除非其它特殊要求, 本产品规格书规定的测试条件为: 温度 25±2℃, 相对湿度 45%~85%。温度 25~35℃ 或者相对湿度 25~85%对测试结果没有明显影响。

4.2 Measuring Instrument or Apparatus 测试设备要求

4.2.1 Dimension Measuring Instrument 尺寸测量设备

The dimension measurement shall be implemented by instruments with equal or more precision scale of 0.01mm.

测量尺寸的仪器的精度应不小于 0.01mm.

4.2.2 Voltmeter 电压表

Standard class specified in the national standard or more sensitive class having inner impedance more than 10KΩ/V.

国家标准或更灵敏等级,内阻不小于 10KΩ/V.

Guangdong Micro Power New Energy CO., Ltd

Specifications for 21700-5000mAh

4.2.3 Ammeter 电流表

Standard class specified in the national standard or more sensitive class. Total external resistance including ammeter and wire is less than 0.01Ω .

国家标准或更灵敏等级，外部总内阻包括电流表和导线应小于 0.01Ω 。

4.2.4 Impedance Meter 内阻测试仪

Impedance shall be measured by a sinusoidal alternating current method(1kHz LCR meter).

内阻测试仪测试方法为交流阻抗法(AC 1kHz LCR).

4.3 Standard Charge 标准充电

Test procedure and its criteria are referred as follows 测试要求及标准如下:

$0.2CmA=1000mA$

Full charge condition: Constant current $0.2CmA$, Constant voltage $4.40V$ to $0.02CmA$ at $25\pm 2^\circ C$.
 $25\pm 2^\circ C$ 环境下充电， $0.2CmA$ $4.40V(CC-CV)$ 截止电流为 $0.02CmA$ 。

4.4 Rest Period 搁置时间

Unless otherwise defined, 10min, rest period after charge, 10min, rest period after discharge.

如无特殊要求，电芯充放电间隔为 10min。

4.5 Initial Performance Test 初始性能测试

Item 项目	Measuring Procedure 测试方法	Requirements 要求
(1) Open-Circuit Voltage 开路电压	The open-circuit voltage shall be measured within 24 hours after standard charge. 标准充电后 24 小时内测试。	$\geq 4.25V$
(2) AC Impedance Resistance 交流内阻	The Impedance shall be measured in an alternating current method (1kHz LCR meter) after standard charge at $25\pm 2^\circ C$. $25\pm 2^\circ C$ 环境下，标准充电后用交流阻抗法测试。	$\leq 60m\Omega$
(3) Rated Capacity at $0.2C$ (Min) 最小额定容量	The capacity on $0.2CmA$ discharge shall be measured after standard charge at $25\pm 2^\circ C$ (specified C5). $25\pm 2^\circ C$ 环境下，标准充电后以 $0.2CmA$ 恒流放电至截止电压时所放出的容量。	$\geq 5000mAh$

Guangdong Micro Power New Energy CO., Ltd

Specifications for 21700-5000mAh

4.6 Electrical Performance 电性能

4.6.1 Temperature Dependence of Capacity (Discharge) 放电温度特性

Cells shall meet the discharge capacity requirements listed in the below table under respective discharge temperatures. The capacities are to be measured with constant discharge current 0.5CmA (2.75V cut-off) after standard charge at $25 \pm 2^\circ\text{C}$.

电芯在 $25 \pm 2^\circ\text{C}$ 标准充电，然后在 30 分钟内冷却或加热到测试温度。放电前电芯在此温度下保持 2.5 小时，放电电流为 0.5CmA（截止电压 2.75V），做完一个温度实验后，电芯在室温下放置 2h，然后进行充电（ $25 \pm 2^\circ\text{C}$ ），要求如下：

Discharge Temperature 放电温度	-0 $^\circ\text{C}$	25 $^\circ\text{C}$	55 $^\circ\text{C}$
Discharge Capacity 放电容量	70%	100%	95%

4.6.2 Cycle Life 循环性能

30min rest period after standard charge, 0.2C discharge to a cut-off voltage of 3.0V, 30min rest period, the capacity shall be measured after 300 cycles of standard charge and discharge at $25 \pm 2^\circ\text{C}$.

Capacity retention $\geq 70\%$

标准充电后，搁置 30min，0.2C 放电至 3.0V，搁置 30min，测试温度 $25 \pm 2^\circ\text{C}$ ，重复上述步骤进行循环 300周后，对比首次放电容量，（影响电芯循环性能的重要参数），要求如下：

容量保持率 $\geq 70\%$

4.6.3 Long Time Storage Characteristics 长期贮存性能

After about half charge after a period of storage at $25 \pm 2^\circ\text{C}$ for one year(365 days). The remaining available capacity is $\geq 85\% C_5$. The capacity is determined with the capacity of the by the most of preceding three cycles.

贮存前给电芯充入约 50%的容量，然后在 $25 \pm 2^\circ\text{C}$ 的环境条件下开路搁置 365 天，0.2CmA 循环3次，测试恢复容量（3周循环的最大放电容量），容量恢复率 $\geq 85\%$ 。

Guangdong Micro Power New Energy CO., Ltd

Specifications for 21700-5000mAh

4.6.4 Shelf Life 荷电保持能力

Item 项目	Measuring Procedure 测试方法	Requirements 要求
Storage Characteristics 常温贮存	1 The capacity on 0.2CmA discharge shall be measured after standard charge and then storage at $25\pm 2^{\circ}\text{C}$ for 30 days. 标准充电后电芯在 $25\pm 2^{\circ}\text{C}$ 的环境中贮存 30 天，测试 0.2CmA 放电容量（容量保持）	Remaining Capacity $\geq 90\% C_5$ 容量保持率 $\geq 90\%$
	2 After above measured Remaining capacity, the capacity on standard discharge shall be measured after standard charge. 0.5CmA 循环 3 次，测试恢复容量（3 周循环的最大放电容量）	Recovery capacity $\geq 96\% C_5$ 容量恢复率 $\geq 96\%$

4.7 Mechanical Performance 机械性能

Item 项目	Measuring Procedure 测试方法	Requirements 要求
Vibration test 振动测试	After standard charge, the Cell is to be tested as following conditions: Amplitude:0.8mm Frequency:10~55Hz(sweep:1Hz/min) Direction: X/Y/Z axis for 90~100min. The cell is to be tested in three mutually perpendicular to each axis. 标准充电后，对电芯施加振幅 0.8mm，频率变化 1Hz/min，频率范围 10~55Hz 的简谐振动，振动时间约 90~100min。	No fire, no explosion, no smoking is obtained. 不起火，不爆炸，不冒烟
Drop Test 自由跌落	Drop the cell in the shipment condition(full-charge)from 1m height onto 5cm or thicker concrete with p-tile on it 3 times each of X, Y, and Z directions at $25\pm 2^{\circ}\text{C}$ 在 $25\pm 2^{\circ}\text{C}$ 的环境条件下，将电芯进行 3 次从 1.0m 高度的位置自由跌落到水泥板上的试验。	No fire, no explosion, no smoking is obtained. 不起火，不爆炸，不冒烟
挤压测试 Crush test	Fully charged the battery in accordance with standard charge condition, the battery is to be crushed between two flat plates. Continuous to applied force on battery of 13kN(17.2Mpa),stopped until a pressure reading of 17.2Mpa is reached on the hydraulic ram 电池按标准充电条件充满电，放置在两块平面金属板间，持续施加 13KN（17.2Mpa）的压力，直到液压缸施加的压力达到 13KN（17.2Mpa）时停止。	No explosion, no fire. 不爆炸，不起火

Guangdong Micro Power New Energy CO., Ltd

Specifications for 21700-5000mAh

4.8 Safety Performance 安全性能

Item 项目	Measuring Procedure 测试方法	Requirements 要求
Short-Circuit Test 短路测试	After standard charge, the cell is to be short-circuited by connecting the positive and negative terminals of the cell with copper wire having a maximum resistance load of 0.1Ω. 标准充电后，电芯应在外电路总电阻不大于 0.1Ω 的铜线连接下进行短路试验。	No explosion, no fire. The temperature of the exterior cell casing shall not exceed 150°C. 不爆炸，不起火，电芯外部温度不超过 150°C
Heating Test 热冲击	A cell is to be heated in a gravity convection or circulating air oven. The temperature of the oven is to be raised at a rate of 5±2°C/min to a temperature of 130±2°C at which temperature the oven is to remain for 30 minutes before the test is discontinued. 将电芯放于热箱中，温度以 5±2°C/min 的速率升至 130±2°C 并保温 30min.	No explosion, no fire. 不爆炸，不起火
Abnormal Charging Test 过充电	After standard charge, the cell is subjected to a charging current by connecting it to a dc-power supply. The beginning current is 1.0C, which is to be obtained by connecting a resistor of specified size and rating in series with the cell, the voltage of the dc-power supply is 4.6V. The test time is 2.5 hours. This does not require that the initial I _c be maintained for 2.5 hours. 标准充电后，将电芯正负极连接于恒压电源，设置电流为 1.0C，电压为 4.6V，然后对电芯以 1.0C 充电，直至电压达到 4.6V，并恒压保持 2.5 小时。	No explosion, no fire. 不爆炸，不起火

⑥ Storage And Others 贮存及其它事项

6.1 Long Time Storage 长期贮存

If stored for a long time(exceed three months), the cell should be stored in drying and cooling place. And the cell is to be stored in a condition as following.

The environmental condition should be: Temperature: 25±2°C, Humidity: 65±20%RH

It should be noted that the cell would be at an over-discharged state (the voltage below 2.75V/cell) by its self-discharge characteristics in case the cell is not used for long time. In order to prevent over-discharging, the cell shall be charged periodically to maintain between 3.8V and 3.9V.

长期贮存的电芯（超过 3 个月）须置于干燥、凉爽处。

且贮存要求如下：须置于温度为 25±2°C、湿度为 65±20%RH 的环境中。

需要注意的是，在电芯长期未使用期间，它可能会用其自放电特性而处于某种过放电状态（电芯电压低于 2.75V）。为防止过放电的发生，电芯应定期充电，将其电压维持在 3.8V 至 3.9V 之间。

6.2 Others 其它事项

Any matters that this specification does not cover should be conferred between the customer and Micro.

任何本说明书中未提及的事项，须经双方协商确定。

7 Handling Instructions 电芯使用指南

Read and observe the following warnings and precautions to ensure correct and safe use of Li-ion cells.

认真阅读下面的注意事项，确保正确安全使用锂离子电芯。Micro 对违反下述注意事项而产生的任何问题不予负责。

Danger!

Failure to observe the following precautions may result in cell leakage, overheating, explosion and/ or fire.

- Do not immerse the cell in water or allow it to get wet.
- Do not use or store the cell near sources of heat such as a fire or heater.
- Do not use any chargers other than those recommended by Micro .
- Do not reverse the positive(+) and negative(-) terminals.
- Do not connect the cell directly to wall outlets or car cigarette-lighter sockets.
- Do not put the cell into a fire or apply direct heat to it.
- Do not short-circuit the cell by connecting wires or other metal objects to the positive(+) and negative(-) terminals.
- Do not carry or put the cell together with necklaces, hairpins or other metal objects.
- Do not strike, throw or subject the cell to sever physical shock.
- Do not pierce the cell casing with a nail or other sharp object, break it open with a hammer, or step on it.
- Do not directly solder the cell terminals.
- Do not attempt to disassemble or modify the cell in any way.
- Do not recharge the cell near a fire or in extremely hot conditions.

危 险!

不仔细阅读下述事项可能导致电芯泄露、爆炸或起火。

- 勿将电芯投入水中或将其弄湿；
- 勿在热源（如火或加热器）附近使用或贮存电芯；
- 请使用原厂充电器；
- 勿将正负极接反；
- 勿将电芯直接连接到墙上插座或车载点烟式插座上；
- 勿将电芯投入火中或给电芯加热；
- 禁止用导线或其它金属物体将电芯正负极短路，
- 禁止将电芯与项链、发夹或其它金属物体一起运输或贮存；
- 禁止撞击、投掷或者使电芯受到机械震动；
- 禁止用钉子或其它尖锐物体刺穿电芯壳体，禁止锤击或脚踏电芯；
- 禁止直接焊接电芯端子；
- 禁止以任何方式分解电芯；
- 禁止在火源或极热条件下给电芯充电。

Guangdong Micro Power New Energy CO., Ltd

Specifications for 21700-5000mAh

Warning!

Failure to observe the following precautions may result in cell leakage, overheating, explosion and/ or fire.

- Do not place the cell in a microwave oven or pressurized container.
- Do not use the cell in combination with primary cells(such as dry-cells) or cells of different capacity, type or brand.
- Do not use the cell if it gives off an odor, generates heat, becomes discolored or deformed, or appears abnormal in any way. If the cell is in use or being recharged, remove it from the device or charger immediately and discontinue use.
- Keep the cells out of the reach of children. If a child somehow swallows a cell , seek medical attention immediately.
- If the cell leaks or emits an odor, immediately remove it from the proximity of any exposed flame. The leaking electrolyte can ignite and cause a fire or explosion.
- If the cell leaks and electrolyte gets in your eyes, do not rub them. Instead, rinse them with clean running water and immediately seek medical attention. If left as is, electrolyte can cause eye injury.

警告!

不仔细阅读下述事项可能导致电芯泄露、爆炸或起火。

- 禁止将电芯置入微波炉或压力容器中；
- 禁止与一次电芯（如干电芯）或不同容量、型号、品种电芯组合使用；
- 如果电芯发出异味、发热、变形、变色或出现其它任何异常现象时不得使用；如果电芯正在使用或充电，应立即从用电器中或充电器上取出并停止使用；
- 电芯应放在小孩接触不到的地方，如果小孩不小心吞咽电芯 应立即寻求医疗救助；
- 如果电芯泄漏或发出异味，应立即将其从接近明火处移开；
泄漏的电解液可能引起火灾或爆炸；
- 如果电芯漏液后电解液进入眼睛，不要擦，应用水冲洗，立即寻求医疗救助。如不及时处理，眼睛将会受到伤害。

Caution!

Do not use or store the cell where is exposed to extremely hot, such as under window of a car in direct sunlight in a hot day. Otherwise, the cell may be overheated. This can also reduce cell performance and/or shorten service life.

Use the cell only under those environmental conditions described in this document. Failure to do so can result in reduced performance or a shorten service life. Recharging the cell outside of these temperatures can cause the cell to overheat, explode or catch fire.

In cases where children use the cell, instruct them on the contents of the user's guide and keep an eye on them to ensure that the cell is being used correctly.

If the cell leaks and electrolyte gets your skin or clothing, immediately rinse the affected area with clean running water. If left as is, skin inflammation can occur.

For directions on cell installation and removal, read the instruction manual that accompanies the equipment in which the cell will be used.

If a device is not used for an extended period, the cell should be removed and stored in a cool, dry place. Otherwise, resting or reduced performance may occur.

Guangdong Micro Power New Energy CO., Ltd

Specifications for 21700-5000mAh

If the terminals of the cell are dirty, wipe them clean with dry cloth before use. Otherwise, solid electrical contact may not be charged with the equipment, and this can cause power outages or charging to fail.

注 意!

不要使用处于极热环境中的电芯，如阳光直射或热天的车内。否则，电芯会过热，可能着火（点燃），这样就会影响电芯的性能、缩短电芯的使用寿命。

只能在本规格书规定的环境条件下使用电芯，否则将会降低电芯的性能或缩短电芯的使用寿命。在规定之外的温度下充电可能导致电芯过热、爆炸或起火。

当小孩使用电芯时，需要按用户说明书的内容教他们，并密切注意他们确保正确使用电芯。

如果电芯漏液，电解液弄到皮肤或衣服上，立即用流动的水清洗受影响区域，否则可能导致皮肤发炎。阅读电芯的装置说明书，正确进行电芯的安装与拆卸。

如果设备长期不用，将电芯取出并放置在凉爽、干燥的地方，否则，电芯可能生锈或性能变差。

如果电芯的端子变脏，使用前用干布擦干净。否则电芯会接触不良，从而引起能量损耗或无法充电。

8 Period of Warranty 保质期

The period of warranty is 180 days from the date of shipment.

电芯的保质期为出厂后 180 天。

9 Shipment & storage 出厂状况

Cell voltage: 3.90~4.05V.

电芯电压: 3.90~4.05V.

10 Amendment of this Specification 产品规格书的修订

This specification is subject to change with prior notice.

本公司有权对本产品规格书进行修订，在对产品规格书修订后广东小电新能源有限公司将会通知客户。

Fig.1 Dimensional Drawing 外形尺寸图

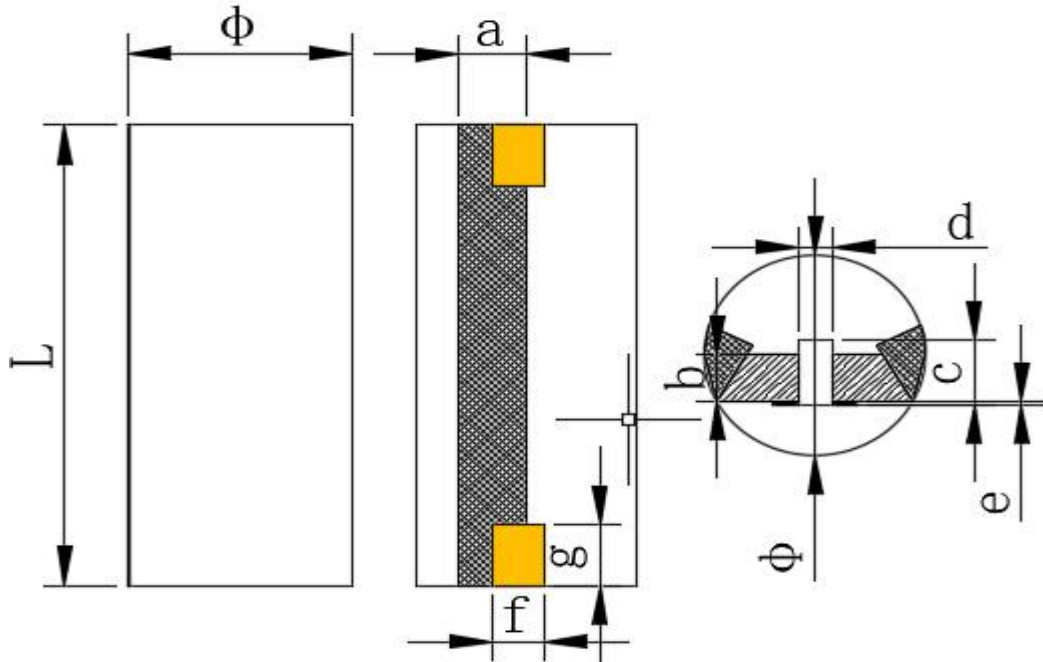

NO. 序号	Test item 检测项目	Technical specifications 技术参数	NO. 序号	Test item 检测项目	Technical specifications 技术参数
1	直径 ϕ	≤ 21.5 mm	8	正极极耳宽度 d	6.0 ± 0.10 mm
2	长度 L	≤ 71.00 mm	9	负极极耳宽度 f	5.0 ± 0.10 mm
3	折边宽度 a	4.0~5.0 mm	10	折边要求	单折边
4	顶封宽度 b	3.0~4.5mm	11	折极耳方式	双折
5	极耳长度 C	3.5 ± 1.50 mm (含极耳胶)	12	极耳胶外露 e	0.2~2.5 mm
6	正极顶部	贴红色青稞纸	13	负极顶部	贴青色青稞纸
7	极耳焊锡时间	360 ± 10 °C, 时间 ≤ 4 S			

Customer Approved/客户确认: