

Specification Approval Sheet 产品规格书

Customer Name 客户名称: _____

Customer Model 客户型号: _____

Customer P/N 客户编号: **NM789**

Product Model 产品型号: **JHY755565PH**

REC P/N 聚和源编号: _____

Prepared by 制作	Checked by 审核	Approved by 批准
刘阳	吕建	唐本升

Customer Approved	Test by 测试	Checked by 审核	Approved by 批准
客户承认 (Stamp) (盖章)			

JUHEYUAN SCIENCE&TECHNOLOGY CO.,LTD.

深圳长虹聚和源科技有限公司

Add: Building 1, 2, 3, No.3, Tianlong Lane, Qingshui Rd, Longxi Community,
Longcheng Street, Longgang District, Shenzhen

Tel: +86-755-84516430

Web: www.jhyenergy.com

Fax: +86-755-84516756 84516178

Email: info@jhypower.com

PRODUCT SPECIFICATION

DOC NO.: NM789-CELL-9462
REV. : 1.00
SHEET : 2 OF 16

Revision History

修改记录

Revision 修改	Description 描述	Date 日期	Approval 批准
1.00	New released	2023/12/1	唐本升

PRODUCT SPECIFICATION

Contents 目录

1.Scope 概述-----	P04
2.Product basic information 产品基本信息-----	P04
3.Cell Outline Drawing 电芯外形尺寸图 -----	P05
4. Electrical characteristics 充放电性能-----	P06
5.Condition adapting characteristics 环境适应性-----	P07
6.Cell safety performance 电芯安全性能-----	P08
7.Others 其他事项-----	P09
8.Testing requirements 测试要求-----	P10
9 Electrical Characteristics 电气特性-----	P10
10.Package 包装图-----	P11
11.Storage 储存-----	P12
12.Transportation 运输-----	P12
13.Cell Precautions and Safety Instructions 电芯使用注意事项及安全说明-----	P12
14.Period of Warranty 保质期-----	P15
Customer Inquiry 客户要求-----	P16

PRODUCT SPECIFICATION

DOC NO.: NM789-CELL-9462

REV. : 1.00

SHEET : 4 OF 16

1. Scope 概述

The specification shall be applied to Lithium-ion Polymer (LIP) rechargeable battery pack which is manufactured by **JUHEYUAN SCIENCE&TECHNOLOGY CO.,LTD.**

此产品规格书适用于深圳长虹聚和源科技有限公司制造的可充电锂离子电池。

Reference standard 参考标准:

GB/T 31241-2022,UN38.3,ROHS2.0

2. Product basic information 产品基本信息

Items 项目	Parameter 参数
Cell model 电芯型号	JHY755565PH
Nominal voltage 标称电压	3.85V
Minimum capacity 最小容量	4970mAh(0.2C charge -0.2C discharge 放电)
Typical capacity 典型容量	5030mAh(0.2C charge-0.2C discharge 放电)
Charging voltage 充电电压	4.4V
Discharging cut-off voltage 放电截止电压	3.0V
Standard charging 标准充电	0.2C /4.4V
Max charging 最大充电	1.0C/4.4V
Standard discharging 标准放电	0.2C/3.0V
Max discharging 最大放电	1.5C/3.0V
Weight 重量	Appr: 72g
Shipment voltage 出货电压	4±0.05V
Cell impedance 电芯内阻	≤ 50mΩ
Max charge current 最大充电电流	0°C~15°C 0.2C max 上限电压4.4V
	15°C~45°C 1.0C max 上限电压4.4V
Max discharge current 最大放电电流	-20≤T<-10°C Max. 0.2C to 3.0V 低温下放电容量低于标准容量
	-10≤T<60°C Max. 1.5C to 2.75V 低温下放电容量低于标准容量
Operating temperature 使用温度	Charging: 0°C ~ 45°C
	Discharging: -20°C ~60°C
Storage (At 50% SOC and specified temp, recoverable capacity in % vs time.) 存储 (50%容量下的存储时间和温度关系)	-10°C~25°C (12 months, ≥85%)
	-10°C ~30°C (6 months, ≥85%)
	10°C~40°C(1month,≥90%) 10°C~40°C(1month,≥90%)
	20±5°C is the recommended storage temperature
	There should not be any remarkable scratches, cracks,

PRODUCT SPECIFICATION

DOC NO.: NM789-CELL-9462

REV. : 1.00

SHEET : 5 OF 16

Visual Inspection 外观

bolts, cauterization, deformations, swelling, leakage and so on on the surface of the cell.

禁止出现诸如撕裂、腐蚀、变形、气鼓、漏液等损害商业价值的不良现象。

3.Cell Outline Drawing 电芯外形尺寸图

项目 Items	描述 Description	尺寸和规格 Dimension and Spec
T	厚度 Thickness	7.55mm max 循环后 Max:8.2mm(4.05V VS 4.05V)-按照第 6 页循环测试标准 (4.3)
W	宽度 Width	55.2mm max
L	长度 Length	65.5mm max (不含极耳胶)
C	极耳胶外露长 Sealant Length	0.2-2.2mm
B	极耳宽度 Tab width	6±0.2mm
L2	极耳中心距 Distance of tab centers	31±1.4mm
L1	极耳长度 Tab Length	8±1mm (含极耳胶)
E	深坑方向	>4.3mm
备注	正对折边面为深坑方向 (左负右正) + 喷码喷浅坑面	
F	顶封边宽度 Top edge width	2±0.6mm

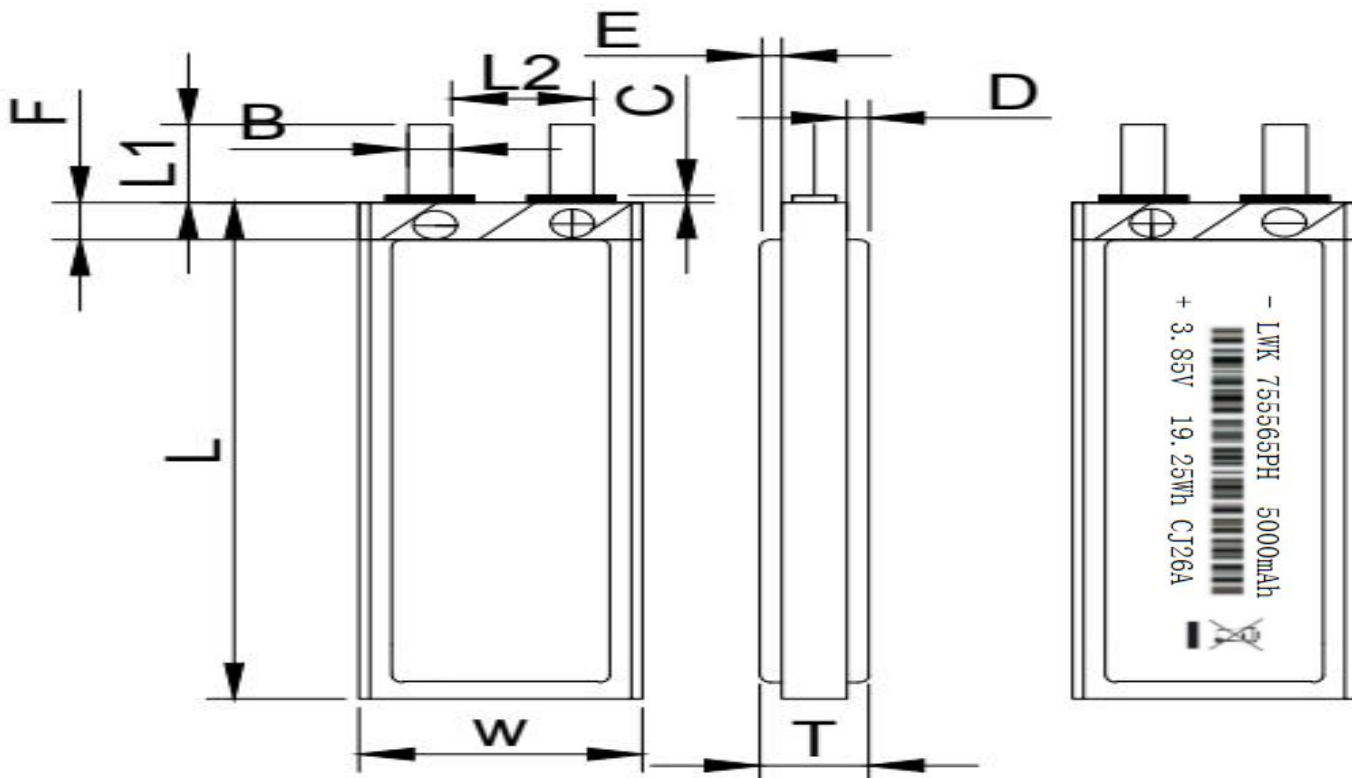

PRODUCT SPECIFICATION

DOC NO.: NM789-CELL-9462

REV. : 1.00

SHEET : 6 OF 16

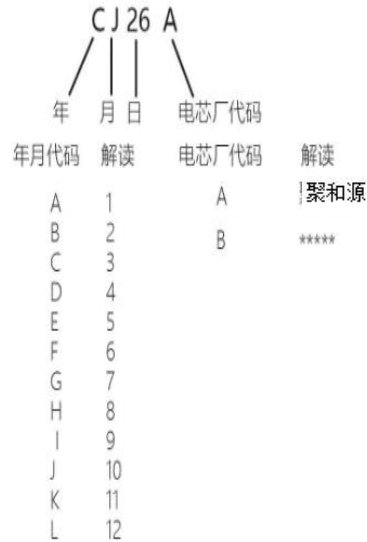

备注：单折边+贴L型侧胶+条形码内容为生产批次+流水码

4. Electrical characteristics 充放电性能

No.	Items 项目	Test Method 测试方法	Criteria 标准
1	Standard Charge 标准充电	Charging the cell initially with constant current at 0.2C and then with constant voltage at 4.4V till charge current declines to 0.02C. 先以 0.2C 恒流充电，当电芯电压达到 4.4V 后，改为恒压充电直到充电电流小于或等于 0.02C。	N.A
2	Minimal Capacity 最小容量	The capacity means the discharge capacity of the cell, which is measured with discharge current of 0.2C with 3.0V cut-off voltage after the standard charge. 电芯满充电后，以 0.2C 电流连续放电至 3.0V 截止电压所放出的容量。	≥4970mAh
3	Charge/Discharge Cycle 充放电循环	The capacity on 0.5C discharge shall be measured after 300 cycles of 0.5C charge and 0.5C discharge at 25±2°C. 25±2°C 条件下，0.5C 充放电循环 300 次。	Capacity≥80% of initial capacity; 容量≥80%;

PRODUCT SPECIFICATION

4	Retention Capability 荷电保持能力	After full charging, storing the cell 28 days with $25 \pm 2^\circ\text{C}$ condition, and then staying 1 hours with discharge current of 0.2C till 3.0V cut-off voltage. 电芯满充电后, 在 $25 \pm 2^\circ\text{C}$ 的环境条件下存放 28 天, 搁置 1h 后以 0.2C 电流连续放电至 3.0V 终止电压。	Capacity $\geq 85\%$ 容量 $\geq 85\%$
---	--------------------------------	---	--

※ **Typical capacity 典型容量**

The capacity means the average discharge capacity of the cell, which is measured with discharge current of 0.2C with 3.0V cut-off voltage after the standard charge at $25 \pm 2^\circ\text{C}$ environment temperature, unit: mAh

典型容量指 $25 \pm 2^\circ\text{C}$ 温度下, 以 0.2C 电流放电至终止电压时所放出容量对应的容量分布中心值, 单位为 mAh。

5. Condition adapting characteristics 环境适应性

No.	Items 项目	Test Method 测试方法	Criteria 标
1	Constant temperature and Humidity 恒定湿热	After standard charging, put cell into the box that the temperature is $40 \pm 2^\circ\text{C}$ and the humidity ranges between 90% ~95% for 48 hours. then put it at $23 \pm 2^\circ\text{C}$ for 2 hours, then discharge with current of 0.2C to the cut-off voltage. 满充电后将电芯放入 $40^\circ\text{C} \pm 2^\circ\text{C}$ 及相对湿度为 90~95% 的恒温恒湿箱中 48 小时后, 取出在 $23 \pm 2^\circ\text{C}$ 环境下搁置 2h, 再以 0.2C 电流放电至 3.0V。	No distortion, no rust, no leakage, no venting, no rupture, no fire, no explosion, the discharge time is not less than 3hrs. 不变形、不锈蚀、不泄漏、不泄气、不破裂、不起火、不爆炸、放电时间不低于 3h。
2	High Temperature Performance Test 高温放电性能	After full charging, put the cell into box with high temperature of $55^\circ\text{C} \pm 2^\circ\text{C}$ for 2h, then discharge with current of 1.0C to the cut-off voltage. 电芯满充电后, 在 $55^\circ\text{C} \pm 2^\circ\text{C}$ 的高温箱中放置 2h, 然后以 1.0C 电流放电至终止电压。	No distortion, no rupture, no fire, smoke or leakage Discharge time ≥ 51 min 电芯不爆裂、不起火、不冒烟、不漏液。 时间 ≥ 51 min
3	Low Temperature Performance Test 低温放电性能	After full charging, put the cell into box with low temperature of $-10^\circ\text{C} \pm 2^\circ\text{C}$ for 4h, then discharge with current of 0.2C to the cut-off voltage. 电芯满充电后, 在 $-10^\circ\text{C} \pm 2^\circ\text{C}$ 的低温箱中放置 4h, 然后以 0.2C 电流放电至终止电压。	No distortion, no rupture, no fire, smoke or leakage Discharge time ≥ 3 h 电芯不爆裂、不起火、不冒烟、不漏液。 放电时间 ≥ 3 h

PRODUCT SPECIFICATION

DOC NO.: NM789-CELL-9462

REV. : 1.00

SHEET : 8 OF 16

6. Cell safety performance 电芯安全性能

No.	Items 项目	Test Method 测试方法	Criteria 标准
1	Cell Overcharge 电芯过充	After discharge to limit voltage, charged at constant current of 3C and constant voltage of 4.6V, While voltage reaches to the max ,if charging continued over 7 hours or temperature is 20% less than the top , close the test . 电芯放电至终止电压后,用 3C 电流和 4.6V 的极限电压充电,电压达到最大值后,当充电时间大于 7h 或者温度降至比峰值低 20%时终止测试。	No explosion and no fire. 无起火、爆炸
2	External Short-circuit Test 外部短路	Cell terminals are short-circuited to discharged state less than 0.1V or longer time with a resistance of 80mΩ or less. Tests are to be conducted at room temperature. 在室温环境中,将电芯的端口用 80±20mΩ 电路相连接,直到电芯放电电压≤0.1V。	No explosion and no fire. 无起火、爆炸
3	Over-Discharge Test 过放电	Cell is discharged at a current of 1C rate for 2.5 hours. (If current stops by safety or passive circuit on the cell, test is finished.) 用 1C 的电流放电 2.5 小时(如果电芯由于安全保护启动致电芯放电停止,则测试完成)。	No explosion and no fire. 无起火、爆炸
4	Crush Test 挤压	Crush between two flat plates. Applied force is about 13KN. 电芯置于两个平板中,对平板施加用 13KN 的压力对电芯进行挤压。	No explosion and no fire. 无起火、爆炸
5	Drop 自由跌落	After standard charging, the cell is to be dropped from a height of 1.2 meter onto a thickness of 20mm board, dropped once in the positive and negative directions of three mutually perpendicular X, Y, Z axes. 满充电电芯从 1.2 米高处自由跌落到 20mm 厚的硬木板上,从 X, Y, Z 正负方向每个方向自由跌落一次。	No leakage, no smoke, no fire , no explosion. 无漏液、冒烟、起火、爆炸

PRODUCT SPECIFICATION

DOC NO.: NM789-CELL-9462

REV. : 1.00

SHEET : 9 OF 16

6	Vibration Test 振动	Fixed the fully charged cell to vibration table and subjected to vibration cycling that the frequency is to be varied at the rate of 1Hz per minute between 10Hz and 55Hz, the excursion of the vibration is 0.8mm. The cell shall be vibrated for 90 ~100minutes per axis of XYZ axes. 电芯按照振幅为 0.8mm 的谐振形式进行振动。振动频率在 10 和 55Hz 间以 1Hz / min 的速率变化，往复振动 90 ~ 100mins。电芯应该在互相垂直的三个面进行测试。	No explosion, no fire, no leakage. 无起火、爆炸、漏液
7	Heating 热冲击	After standard charging, put cell in the baking oven and start , the temperature of the oven is to be raised at a rate of 5±2 °C per minute to a temperature of 130±2°C ,remain for 30minutes at that temperature. 将电芯满充电后，放置于热箱中，温度以（5±2°C）/ min 的速率升至 130°C±2°C并保温 30min。	No explosion and no fire. 无起火、爆炸

7. Others 其他事项

7.1 材料重量估算值

材料种类	大约重量(估计值)	大约重量占比（估计比列）
正极主材	29.6g	41.1%
负极主材	17.2g	23.9%
电解液	7.1g	9.9%
隔膜	2.3g	3.23%
铝塑膜	2.7g	3.75%
铜箔	5.7g	7.9%
铝箔	3.6g	5%
导电剂	0.5g	0.7%
粘结剂	0.7g	0.97%
其他	2.6g	3.6%

备注：以上材料比列为粗略估算值。实际存在偏差值

7.2 认证标准

满足UN38.3、GB31241-2022.其他认证协商沟通

Any matters that this specification doesn't cover should be conferred between the customer and JHY.

任何本规格书中未提及的事项，需要经双方协商确定。

8. Testing requirements 测试要求

8.1 Cell test environment 电芯试验环境

Temperature 温度: $23\pm 2^{\circ}\text{C}$

Relative humidity 相对湿度: $60\pm 20\%$ RH

Atmospheric pressure 大气压力: $86\sim 106$ KPa

8.2 Measuring instrumentation requirements 测量仪表要求

Voltage instrumentation requirements: Measuring the voltage meter accuracy no less than 0.5 magnitude

电压仪表要求: 测量电压的仪表的精确度不低于 0.5 级

Current instrumentation requirements: Measuring the current meter accuracy no less than 0.5 magnitude

电流仪表要求: 测量电流的仪表精确度不低于 0.5 级

Time instrumentation requirements: Measuring the time meter accuracy no less than 0.1%

时间仪表要求: 测量时间的仪表精确度不低于 0.1%

Temperature instrumentation requirements: Measuring the temperature meter accuracy no less than 0.5°C

温度仪表要求: 测量温度的仪表准确度不低于 0.5°C

Impedance instrumentation requirements: Measuring impedance should by sinusoidal alternating (1 KHZ) test

内阻仪表要求: 测量内阻应由正弦交变(1KHZ)进行测试

9. Electrical Characteristics 电气特性

9.1 Cell charge/discharge 电芯充/放电

9.1.1 Full charged definition 充饱定义

With charging voltage 4.4V, current 0.2C continued to charge the cell, when charging current drops to 0.02C charging is terminated, shall be full charged.

以充电电压4.4V, 电流0.2C对电芯持续充电, 当充电电流下降至0.02C 时充电被终止, 即为充饱。

9.1.2 Full discharged definition 放空定义

Standard discharge current 0.2 C for continuous discharge, when the voltage drops to discharge cut-off voltage 3.0V discharge is terminated, shall be full discharged.

以标准放电电流 0.2 C 进行持续放电, 当电压降至放电截止电压 3.0V 时放电被终止, 即为放空。

PRODUCT SPECIFICATION

DOC NO.: NM789-CELL-9462

REV. : 1.00

SHEET : 11 OF 16

10. Package 包装图

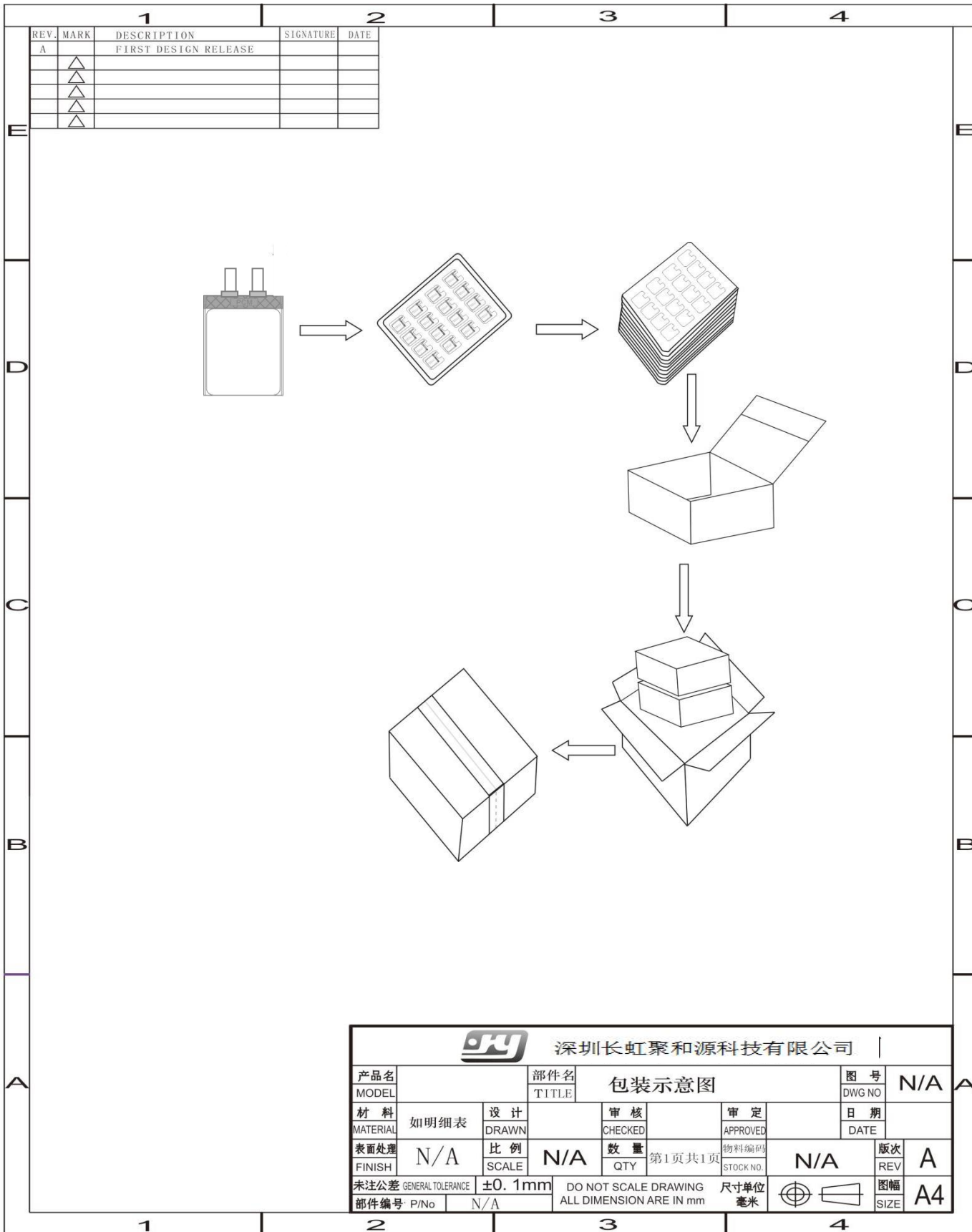

11.Storage 储存

- ◆The Li-ion cell should be stored in a cool, dry and well-ventilated area, and should be far away from the fire and the high temperature.

锂电芯需保存在阴凉、干燥、通风的环境中，避免接触火源与热源。

- ◆The cell should store in the product specification book stipulation temperature range, the best storage temp. is $25\pm 5^{\circ}\text{C}$. The best humidity is $60\pm 15\%$.

电芯需按规格书规定温度范围进行储存，最佳储存温度为 $25\pm 5^{\circ}\text{C}$ ，最佳湿度为 $60\pm 15\%$ 。

- ◆The cell should be stored within room temperature, and charged to 40%~60% electric quantity (3.85V) . In order to avoid over-discharge, we suggest charge and discharge the cell every three months. Then charge to 40%~60% electric quantity(3.85V).

电芯应当在室温下存放，应充到 40%~60%的电量(3.85V)。为防止电芯过放，建议每 3 个月按标准充电方式进行一次充电，然后按标准充电方式进行充电至 40%~60%的电量（3.85V）。

12.Transportation 运输

- ◆Do not mix the cell products with other cargos.

请勿与其他货物混合。

- ◆Do not immerse the cell products in water or allow it to get wet.

请勿将电芯浸入水中或使其受潮。

- ◆Do not over 7 layers staking and upside-down.

请勿叠放超过 7 层或倒置。

- ◆The highest temperature in transportation is lower than 65°C .

最高运输温度不超过 65°C 。

13.Cell Precautions and Safety Instructions 电芯使用注意事项及安全说明

Please be sure to take to comply with the specifications and the following precautions to use the cell , did not follow the specifications for the operation caused any accidents, JUHEYUAN SCIENCE&TECHNOLOGY CO.,LTD. will not accept any responsibility.

请您务必需遵守本规格书和以下使用注意事项使用电芯，对于没有按照规格书进行操作所造成的任何意外事故，聚和源科技有限公司将不承担任何责任。

13.1 Warnings 警告

- ◆Keep the cell away from fire .

电芯应远离火源。

PRODUCT SPECIFICATION

DOC NO.: NM789-CELL-9462

REV. : 1.00

SHEET : 13 OF 16

◆Do not put the cell in a charger or equipment with wrong terminals connected.

不可将电芯充电器正负极反接。

◆Avoid shorting the cell.

不可将电芯短路。

◆Avoid excessive physical shock or vibration.

避免电芯过度冲击和震荡。

◆Do not disassemble or deform the cell.

不可拆解或扭曲电芯。

◆Do not immerse in water.

不可浸入水中。

◆Do not use the cell mixed with other different type or model cell.

不可将该电芯与其他种类和型号的电芯混用。

◆Keep out of the reach of children.

请置于儿童接触不到的地方。

13.2 Charge 充电

◆Cell must be charged in appropriate charger only.

请使用合适的充电器对电芯充电。

◆Never use a modified or damaged charger.

请勿用返修或损坏过的充电器充电。

◆Do not leave cell in charger over 24 hours.

请勿对电芯充电 24H 以上。

◆Can not surpass the biggest charging current which in this specification book stipulated.

不可使用超出本规格书最大充电电流对电芯进行充电。

◆Does not have to surpass the highest amount which in this specification book stipulated to decide the voltage.

请不要超出本规格书所规定最高充电电压。

◆The cell must carry on the charge in the ambient temperature scope which this specification book stipulated.

电芯需在指定温度范围内进行充放电。

◆Uses constant current and constant voltage way charge. PLS connect the positive and negative terminals in right way, otherwise the cell may be damaged.

请使用恒流恒压方式进行充电。请勿反接正负极，以免损坏电芯。

13.3 Discharge 放电

- ◆ The discharging current should not surpass the biggest discharging current this specification book stipulation, The large discharge current can cause heat and lower capacity.

放电电流不可超过规格书最大额定放电电流。大电流会导致电芯发热和容量降低。

- ◆ The cell discharge must carry on in the ambient temperature scope which this specification book stipulated. 电芯必须在规格书规定温度范围内放电。

- ◆ After short time over discharge, then charge immediately won't damage the cell. But the cell will be damaged for being long time over discharged. During long-term storage, the cell may be within over-discharging condition for self discharge. To prevent the occurrence of over discharging, the cell should maintain the certain capacity when storage.

电芯瞬间过放后立即充电不会损坏电芯。但是如果长时间过放，电芯将会被损坏。在长期储存中，可能由于电芯自放电而导致电芯处于过放状态。因此为避免电芯过放，必须带电储存。

13.4 Handling of Cell 电芯操作注意事项

- ◆ Soft Al foil (铝箔软包装)

Don't strike cell with any sharp edge part.

勿用尖锐处撞击电芯。

Trim your nail or wear glove before taking cell.

剪掉指甲，或者戴手套。

Clean worktable to make sure no any sharp particle.

清理工作台，避免尖锐零部件。

Sealed edge may be damaged by heat above 100°C, bend or fold sealed edge.

封边被加热到 100°C 以上以及弯折封边都容易使封边受损。

Avoid some components to contact the edge of packing foil of cell

避免导电元件与电芯包装铝箔的直接接触

- ◆ Handling of Tabs (极耳操作注意事项)

The cell tabs are not so stubborn especially for aluminous tab.

Do not bend tabs unnecessarily.

极耳的机械强度并非异常坚固，特别是铝极耳。没有必要时禁止弯折极耳。

- ◆ Tab Connection (极耳连接)

Ultrasonic welding or spot welding is recommended for LIP tab connection method.

PRODUCT SPECIFICATION

DOC NO.: NM789-CELL-9462

REV. : 1.00

SHEET : 15 OF 16

Cell should be designed that shear force are not applied to the LIP tabs.

If apply manual solder method to connect tab with PCM, below notice is very important to ensure cell performance.

The solder iron should be temperature controlled and ESD safe.

Soldering temperature should not exceed 370°C.

Soldering time should not be longer than 3s.

Soldering times should not exceed 5 times, Keep cell tab cold down before next time soldering.

Directly heat cell body is strictly prohibited, Cell may be damaged by heat above approx. 100°C.

建议使用超声波或点焊焊接方法；外壳设计应使极片不受外力。

如果使用人工焊接保护板，下面的注意事项对于确保电芯性能非常重要：

焊接铬铁的温度必须可控且可防静电；

焊接时铬铁的温度不能超过 370°C；

焊锡时间不能超过 3 秒钟；

焊锡次数不能超过 5 次，待极片冷却后才能进行下一次焊锡；

严禁直接加热电芯，高于 100°C 度会损害电芯。

13.5 Disposal 处理措施

Regulations vary for different countries. Dispose of in accordance with local regulations.

不同国家有不同规定。请按当地规定进行处理。

14. Period of Warranty 保质期

The period of warranty is one year from the date of shipment. JHY guarantees to give a replacement in case of cell with defects proven due to manufacturing process instead of the customer abuse and misuse.

电芯的保质期从出货之日算起为一年。如果证明电芯的缺陷是在我们公司制造过程中造成的而不是客户滥用或错误使用造成，本公司负责退换电芯。

PRODUCT SPECIFICATION

DOC NO.: NM789-CELL-9462

REV. : 1.00

SHEET : 16 OF 16

Customer Inquiry

客户要求

1. IF clientele ratify specification and showpiece, please sign back specification to JHY in 1 week, 如果客户认可规格书和样品，请下订单前及时回签规格书给聚和源公司
- 2、The customer is requested to write down your information and contact JHY in advance, if and when the customer needs applications or operating conditions other than those described in this document.JHY could design and build such products according to your special request.

如果客户需要其他方面的说明或工作条件与规格书内容不一致,请客户提前和聚和源公司联系. 聚和源公司将按照贵公司特殊要求设计和开发产品.特殊要求标准:

	Special Request 特殊要求	Criteria 标准
1		
2		
3		
4		
5		
6		

Company Name : _____ Signature : _____ Date: _____

公司名称

签名

日期