



吉安市优特利科技有限公司  
JIAN UTILITY TECHNOLOGY CO., LTD  
深圳市优特利能源股份有限公司  
SHENZHEN UTILITY ENERGY CO., LTD.

编号: UTL-SPE-YZ-043

版本: 01

页码: 第 1 页, 共 13 页

# 锂离子电芯规格书

## Specification For Lithium-ion Rechargeable Cell

客户 Customer:

类别 Type: 锂离子电池 Lithium-ion batteries

型号 Model: UWN18650C1-2000mAh

样品数量 Sample quantity: PCS

编拟 Drafted by:

日期 Date: 2023-04-23

审核 Checked by:

日期 Date: 2023-04-23

批准 Approval by:

日期 Date: 2023-04-23

客户 Customer

生效日期 Effective Date: \_\_\_\_\_

客户印章 Customer seal: \_\_\_\_\_





## 目录 (Contents)

1	.....	适用范围 Application	第 4 页
2	.....	主要性能指标 Main performance indicators	第 4 页
3	.....	测试条件 Test Condition	第 5 页
4	.....	尺寸及外观 Size and appearance	第 6 页
5	.....	技术要求 Technical characteristics	第 7 页
6	.....	注意事项 Matters needing attention	第 10 页
7	.....	激活 Activate	第 12 页
8	.....	包装 Package	第 12 页
9	.....	保质期 Period of Warranty	第 13 页
10	.....	电池存放 Storing the Batteries	第 13 页
11	.....	产品责任 Product liability	第 13 页
12	.....	联系方式 Contact information	第 13 页
13	.....	注释 Note	第 13 页



## 1. 适用范围 Application

本规范描述了本公司生产的可充锂离子电池的有关参数要求和检验规则;

本规范符合国家 GB 31241-2014 便携式锂离子电池和电池组安全要求。

This Specification is applied to UTL rechargeable lithium ion battery of the steel shell cylinder type for various applications in mobile communication devices and portable power systems;The specification is based on the technical specification of GB 31241-2014.

## 2. 主要性能指标 Main performance indicators

表 1 主要性能指标 Main performance indicators

项目 Item	指 标 Specification	备 注 Remarks
型号 Model	UWN18650C1	锂离子电池 lithium-ion batteries
额定容量 Nominal Capacity	2000mAh (0.2C)	0.2C <sub>5</sub> A 放电 0.2C <sub>5</sub> A discharge
最小容量 Minimum capacity	1950mAh (0.2C)	0.2C <sub>5</sub> A 放电 0.2C <sub>5</sub> A discharge
标称电压 Nominal Voltage	3.7V	
内阻 Internal Impedance	≤20mΩ	
标准充电电流 Charging Current(Std.)	970mA	0.5C <sub>5</sub> A
连续最大充电电流 Continuous Max. Charge Current	1950mA	1.0C <sub>5</sub> A
标准放电电流 Standard Discharge	390mA	0.2C <sub>5</sub> A
最大持续放电电流 (Max) Sustained Discharging Current	19500mA	10.0C <sub>5</sub> A
充电截止电压 Charging Voltage	4.20±0.05V	
放电截止电压 Discharging Voltage	2.75±0.05V	
充电模式 Charging mode	恒流/恒压截止电流 40mA, Constant current / constant pressure, cut off 40mA	
工作温度 Operating Temperature	Charge	-20 ~ 60℃
	Discharge	-40 ~ 85℃
储存温度 Storage temperature	存储 Storage(≥60℃存储时, 最大充电电压 ≤4.05V ≥60℃ storage, maximum charge voltage ≤4.05V 容量恢复率 > 80%; The 80% or more of capacity recovery rate	
	-40 ~ 85℃	15 天 15day
	-40 ~ 60℃	30 天 30day
	-20 ~ 45℃	0~3 个月 0~3month
	-20 ~ 25℃	0~12 个月 0~12months
最大充电电流 Maximum charge Current	-20℃~0℃	0.05C to 4.1V
	0℃~10℃	0.2C to 4.1V
	10℃~45℃	1.0C to 4.2V
	45℃~60℃	0.5C to 4.1V
最大放电电流 Maximum discharge Current	-40℃~-20℃	1.0C to 2.0V (Max1C)
	-20℃~10℃	3.0C to 2.5V (Max3C)
	10℃~45℃	10.0C to 2.75V (Max10C)



吉安市优特利科技有限公司  
JIAN UTILITY TECHNOLOGY CO., LTD  
深圳市优特利能源股份有限公司  
SHENZHEN UTILITY ENERGY CO., LTD.

编号: UTL-SPE-YZ-043

版本: 01

页码: 第 5 页, 共 13 页

	45℃~85℃	1.0C to 2.75V (Max1C)
存储湿度 Storage Humidity	≤75%RH	
出货电压 Factory Voltage	1)空运: 3.50~3.65V For air transport: 3.50~3.65V 2)非空运: 3.75~3.95V Other transport: 3.75~3.95V	
电池尺寸 Outline dimension	MAX:18.5mm*65.4mm	包含 PET 套膜 Includes PET Saving
重量 Weigh	约 42.0g About 42.0g	
表征温度	电芯表面温度不允许超过 90℃ The cell temperature is not allowed to be higher than 90℃	

### 3. 测试条件 Test Condition

温度 Temperature: 25±5℃

相对湿度 Relative Humidity: 45%~75%

大气压力 Atmospheric Pressure: 86kPa~106kPa

#### 3.1 测量仪表与设备要求 Measuring meters & Instruments

3.1.1 测量电压的仪表精度应不低于 1%。

Voltmeter should be up to grade 1% in precision.

3.1.2 测量电流的仪表精度应不低于 1%。

Ammeter should be up to grade 1% in precision.

3.1.3 测量时间的仪表相对误差为±0.1%。

Hour-meter should have a precision of ±0.1% or higher

3.1.4 恒流负载在被测电源电压范围内恒定电流可调, 其电流相对误差为±1%。

The current of a constant-current supply should be stable and adjustable. Its variation shall be within ±1% during the charging and discharging process.

3.1.5 充电电源 (或充电器) 在电池电压达到充电电压恒压值后应能改为恒压充电。

Charging power supply(or charger) should be changed to constant voltage charging when battery voltage reaches constant voltage value

3.1.6 量具精度: 0.02mm。

Measuring precision: 0.02 mm.



## 4. 尺寸及外观 Size and appearance

### 4.1 电芯尺寸 Core Size

(直径 Diameter)  $A \leq 18.5\text{mm}$

(高度 Length)  $B \leq 65.4\text{mm}$

电芯尺寸示意图如图 1 所示 (单位: mm)。

The diagram of the size of the core is shown in Figure 1(in mm).

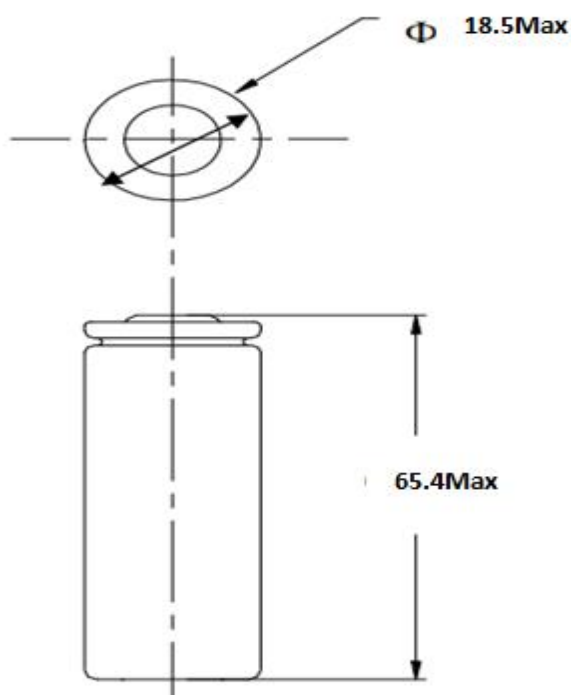

Figure 1/ 图 1

### 4.2 电池外表面内容 External surface content of the battery

电芯外观套膜颜色: Battery set film color:.

喷码内容: 根据客户具体要求执行 Spray a code contents: Concretely request to carry out according to the customer

### 4.3 电池外观 Battery appearance

电池外表面清洁, 无电解液泄露, 无明显的花痕迹机械损伤, 无变形, 无影响电池价值的其他外观缺陷。

The outer surface of the battery is clean, there is no leakage of electrolytes, no obvious mechanical damage of flower marks, no deformation, and no other appearance defects that affect the value of the battery.



## 5. 技术要求 Technical characteristics

### 5.1 电性能 Electrical Characteristics

序号 number	检测项目 Item	测试条件与方法 Test conditions and methods	性能标准 Performance standards
5.1.1	标准充电 Standard Charging	<p>指在 <math>25 \pm 2.5^\circ\text{C}</math> 环境下，以 <math>0.5\text{C}</math> 的电流恒流充电至单体电芯电压 <math>4.2\text{V}</math> 后，转为恒压 <math>4.2\text{V}</math> 充电，至充电电流小于 <math>0.02\text{C}</math> 时，停止充电。</p> <p>The charger supplies <math>0.5\text{C}_5\text{A}</math> constant current until battery voltage reaches <math>4.2\text{V}</math>, then be changed at constant voltage of <math>4.2\text{V}</math> while tapering the charge current to less than or equal to <math>0.02\text{C}_5\text{A}</math>.</p>	-----
5.1.2	标准放电 Standard Discharging	<p>指在 <math>25 \pm 2.5^\circ\text{C}</math> 环境下，以 <math>0.2\text{C}</math> 的电流恒流放电至 <math>2.75\text{V}</math> 终止电压。</p> <p>Refers to the current constant current discharge at <math>0.2\text{C}</math> to <math>2.75\text{V}</math> termination voltage at <math>25 \pm 2.5^\circ\text{C}</math>.</p>	-----
5.1.3	倍率放电 Rate discharge	<p>指在 <math>25 \pm 2.5^\circ\text{C}</math> 环境下，以 <math>0.5\text{C}</math> 倍率将电池充饱电后，搁置 10 分钟，分别以 <math>0.5\text{C}/1.0\text{C}/5.0\text{C}/10\text{C}</math> 倍率放电至 <math>2.75\text{V}</math>。循环三次，当有一次达到标准，即达到标准要求。</p> <p>Refers to the battery being fully charged at a rate of <math>0.5\text{C}</math> at <math>25 \pm 2.5^\circ\text{C}</math> for 10 minutes and discharged to <math>2.75\text{V}</math> at <math>0.5\text{C}/1.0\text{C}/5.0\text{C}/10\text{C}</math>, respectively. The cycle is repeated three times. When there is one meeting the standard, it meets the standard requirements.</p>	放电容量/标称容量*100% Discharge nominal capacity * 100 %
			$0.5\text{C} \geq 99\%$ $1\text{C} \geq 90\%$ $5\text{C} \geq 90\%$ $10\text{C} \geq 90\%$
5.1.4	温度放电 Temperature discharge	<p>指在 <math>25 \pm 2.5^\circ\text{C}</math> 环境下，以 <math>0.2\text{C}</math> 倍率将电池充饱电后，在 30min 之内温度升/降至测试温度。在测试温度下搁置 4H 后，用 <math>0.2\text{C}</math> 放电至指定电压。</p> <p>Refers to the temperature rising / falling to the test temperature within 30 min after charging the battery at a rate of <math>0.2\text{C}</math> at <math>25 \pm 2.5^\circ\text{C}</math>. After shelving 2H at the test temperature, it was discharged with <math>0.2\text{C}</math> to Voltage.</p>	$-40^\circ\text{C} \geq 40\%$ $-30^\circ\text{C} \geq 60\%$ $-20^\circ\text{C} \geq 68\%$ $0^\circ\text{C} \geq 76\%$ $60^\circ\text{C} \geq 95\%$ $85^\circ\text{C} \geq 90\%$
5.1.5	常温荷电 Capacity retention	<p>指在 <math>25 \pm 2.5^\circ\text{C}</math> 环境下，测量电池初始状态和初始容量，电池标准充电后，开路放置 30 天，测量电池最终状态；以 <math>0.2\text{C}</math> 放电至 <math>2.75\text{V}</math>，测量电池剩余容量；<math>0.2\text{C}/0.2\text{C}</math> 测量电池的恢复容量。可循环三次，当有一次达到标准，即达到标准要求。</p> <p>Refers to the initial state and initial capacity of the battery at <math>25 \pm 2.5^\circ\text{C}</math>. After the battery is charged, the open circuit is placed for 30 days to measure the final state of the battery; Measurement of battery residual capacity by <math>0.2\text{C}</math> discharge to <math>2.75\text{V}</math>; <math>0.2\text{C}/0.2\text{C}</math> to measure battery recovery capacity. It can be recycled three times. When there is one meeting the standard, it meets the standard requirements.</p>	剩余容量 $\geq$ 标称容量*85% Capacity retention rate $\geq 85\%$
			恢复容量 $\geq$ 标称容量*95% Capacity recovery rate $\geq 95\%$



5.1.6	循环寿命 Cycle life	<p>指在 25±2.5℃环境下, 以 0.5C 充电之后, 搁置 10 分钟, 用 0.2C 放电至终止电压, 放电结束后搁置 10 分钟, 再进行下一次充放电循环, 连续进行充放电循环 500 次。</p> <p>After full charge at 0.5c at 25±2.5℃, set aside for 10 minutes, discharge at 0.2C until the termination voltage, set aside for 10 minutes after discharge, and then conduct the next charge and discharge cycle for 500 times.</p>	<p>容量保持率≥80%</p> <p>Capacity retention rate ≥ 80%</p>
5.1.7	高温存储性能 Storage performance	<p>指在 25±2.5℃环境下, 测量电池的初始容量, 标准充电至 4.2±0.02V 后, 测量电池存储前的初始状态, 分别不同温度储存 10 天、20 天、30 天, 1000H 后, &gt;60℃存储时, 最大充电电压≤4.05V, 测量电池的容量残余和容量恢复率, 已 0.2C 放电时间表示。</p> <p>Refers to the final state of the battery after being charged to 4.2 ± 0.02 V at different temperature and stored in different time, and the discharge time of the battery at 0.2 C.</p>	<p>0.2C 放电时间</p> <p>0.2C discharge time</p> <p>25℃ 1months(月) 残余时间 ≥255min 恢复时间≥285min</p> <p>(4.20V)60℃ 60days 残余时间 ≥210min 恢复时间≥240min</p> <p>(4.05V)85℃ 40days 恢复时间 ≥240min</p>

5.2 机械性能 Mechanical properties

序号 number	检测项目 Item	测试条件与方法 Test conditions and methods	性能标准 Performance standards
5.2.1	跌落 Free fall	<p>标准充电后电池从 75cm 高度跌落到贴有 5mm 乙烯基瓷砖的混凝土地面上, X、Y、Z 三轴各一次为一个循环, 共三次循环。</p> <p>At room temperature, the battery (4.2V) is dropped on concrete floor covered with vinyl tile of 5 mm thickness from a height of 75 cm. Each direction (X, Y, Z) 3 times.</p>	<p>不爆炸、不起火</p> <p>No explosion, No fire</p>
5.2.2	振动 Vibration	<p>标准充电后电池使用如下条件进行测试:</p> <ul style="list-style-type: none"> <li>• 振动波形 正弦波</li> <li>• 振动频率 16.7Hz</li> <li>• 振动时间 1 小时</li> <li>• 振动方向 任意</li> <li>• 全振幅 1mm</li> </ul> <p>振动后电池进行标准充放电测试。</p> <p>A rated charged battery shall be vibrated as specified:</p> <ul style="list-style-type: none"> <li>• Vibration waveform: sinusoidal</li> <li>• Frequency: 16.7Hz</li> <li>• Test time: 1 hours</li> <li>• Vibration direction: arbitrary</li> <li>• Total amplitude: 1mm</li> </ul> <p>After vibration application, the battery is standard charged, and then standard discharged.</p>	<p>无变形、破裂、发火、可进行充放电</p> <p>No explosion, flame, nor distortion.</p> <p>Charge and discharge is possible.</p>





### 5.3 环境适应性能 Environmental adaptation

序号 number	检测项目 Item	测试条件与方法 Test conditions and methods	性能标准 Performance standards
5.3.1	温度循环 Temperature cycle	<p>电池标准充电后, 在环境温度 <math>85 \pm 2^{\circ}\text{C}</math> 的条件下开路放置 30min, 然后再 <math>-40^{\circ}\text{C}</math> 条件下开路放置 30min, 切换时间 <math>&lt; 15\text{s}</math> 循环 1500 次后最后在室温条件下开路放置 24h, 观察电池外观变化。</p> <p>After the battery is charged, it is placed in the open circuit at an ambient temperature of <math>85 \pm 2^{\circ}\text{C}</math>, then in the open circuit at <math>-40^{\circ}\text{C}</math>, and finally after 1500 cycle, in the open circuit at room temperature, 24 H to observe the changes in the appearance of the battery.</p>	<p>不爆炸、不起火</p> <p>No explosion, No fire</p>
5.3.3	恒温恒湿 Constant temperature and humidity	<p>电池标准充电后, 至于温度为 <math>40 \pm 5^{\circ}\text{C}</math>, 相对湿度为 95% 的恒温恒湿箱中, 搁置 48h, 取出电池搁置 2h, 以 1C 放电至 2.75V。</p> <p>After the battery is charged, the battery is placed on hold in a constant temperature humidity box with a temperature of <math>40 \pm 5^{\circ}\text{C}</math> and a relative humidity of 95 %. The battery is placed on hold for 2 H and discharged to 2.75 V.</p>	<p>无泄漏、无起火</p> <p>No leakage No fire</p>

### 5.4 安全性能 Safety performance

序号 number	检测项目 Item	测试条件与方法 Test conditions and methods	性能标准 Performance standards
5.4.1	过充测试 Overcharge test	<p>电芯按照标准放电方式放完电后, 采用 2.0C 电流 5.0V 电压恒流恒压充电 7.0 小时。</p> <p>After the core is discharged according to the standard discharge method, the 2.0C current 5.0V voltage constant current voltage is used to charge 7.0 hours.</p>	<p>不爆炸、不起火</p> <p>No explosion, No fire</p>
5.4.2	150°C 热箱测试 Hot box test	<p>电芯按照标准充电方式充满电后, 将电芯放进热箱里, 然后将热箱按 <math>5^{\circ}\text{C}/\text{min}</math> 升温到 <math>150^{\circ}\text{C}</math>, 当电芯的温度也达到 <math>150^{\circ}\text{C}</math> 时, 电芯在热箱 <math>150^{\circ}\text{C}</math> 环境下保持 60 分钟或者电芯起火爆炸为止。</p> <p>After the core is filled with electricity according to the standard charging method, the core is put into the hot box, and then the hot box is heated to <math>150^{\circ}\text{C}</math> at <math>5^{\circ}\text{C}/\text{min}</math>. When the core temperature also reaches <math>150^{\circ}\text{C}</math>, The core is kept for 30 minutes in a hot box environment of <math>150^{\circ}\text{C}</math> or the core bursts into flames.</p>	<p>电芯表面温度达到 <math>150^{\circ}\text{C}</math> 后的 60 分钟内, 电芯不起火、不爆炸。</p> <p>The core will not catch fire or explode within 60 minutes after the surface temperature of the core reaches <math>150^{\circ}\text{C}</math>.</p>



5.4.3	挤压测试 Squeeze test	电芯按照标准充电方式充满电后，放在两个平整的表面进行挤压测试，压力器必须施加一个与圆柱电芯轴向垂直的力，平压于电芯。采用 32 mm 直径的液压活塞，所用压力为 13 KN，一旦达到最大压力值，即释放压力。 After the core is fully charged in accordance with the standard charging method, it is placed on two flat surfaces for extrusion testing. The press must apply a force that is perpendicular to the axial direction of the cylindrical core and is pressed flat on the core. Using a 32 mm diameter hydraulic piston, the pressure used is 13 KN, once the maximum pressure value is reached, the pressure is released.	不爆炸、不起火 No explosion, No fire
5.4.4	外部短路测试 External Short - Circuiting Test	电池充满电置于 25°C ±2.5°C 环境下，用外部电阻为 80mΩ±20mΩ的导线将每只电池短路。持续 24h 或外壳温度下降至最高温度的 20%时，结束试验。 The fully charged cells are placed in a test chamber and subjected to the following cycles: short the positive and negative terminals with wire resistance of 80mΩ±20mΩ. Tests are to be conducted at 25°C ±2.5°C, keep 24h or surface temperature decline to 20% of max. temperature, test is end.	不起火、不爆炸，无破裂。 No Fire, No Explosion. Nor distortion
5.4.5	过放测试 Over discharge Test	标准充电后电池以 50Ω 负荷放电 24 小时。 The battery shall be standard charged, and discharged with 50 Ω resistor load for 24 hours.	不爆炸、不起火 No explosion, No fire

## 6. 注意事项 Matters needing attention

### 6.1 电池操作注意事项 Points to Note for Battery Operation

避免电池短路，短路会产生很高的电流而使电池发热以及电解液泄漏，产生有毒气体使非常危险的。极片连接在导电物体表面很容易短路，外部短路会导致发热及损害电池。选用一个适当的保护电路可以在意外短路时保护电池。

To avoid short circuit, short circuit will produce high current to heat the battery and leak the electrolytic fluid, producing toxic gases that are very dangerous. The electrode is connected to the surface of the conductive object and is easily short-circuited. An external short circuit can cause heat and damage the battery. Select a suitable protection circuit to protect the battery in the event of an accidental short circuit.

### 6.2 电池外壳设计注意事项 Points to Note for Battery Shell Design

#### 6.2.1 外壳坚韧度 Shell toughness

电池外壳应该有足够的机械强度，使锂电池免受机械撞击。

The battery case should have sufficient mechanical strength to protect the lithium battery from mechanical impact.

#### 6.2.2 电池的固定电池最大面积的一面应该固定在外壳上，安装后电池不能有松动。

The maximum area of the battery should be fixed to the side of the shell, and the battery should not be loose after installation.

#### 6.2.3 外壳内部设计 Interior design of housing

外壳内安装电池的部位不应有锋锐边。

There should be no sharp edges in the housing where the batteries are installed.

#### 6.2.4 极片连接 Polaroid connection

建议使用点焊焊接方法：外壳设计应考虑使极片不受外力。

The point welding method is recommended: the shell design should be considered so that the electrode is not subjected to external forces.

如果使用人工焊接保护板，下面的注意事项对于确保电池性能非常重要：



The following precautions are important to ensure battery performance if manually welded panels are used:

焊接烙铁的温度必须可控且可防静电；

The temperature of soldering iron must be controllable and anti static;

焊接时对烙铁的温度不能超过 350°C；

The temperature of the soldering iron can not exceed 350 °C during welding;

焊锡时间不能超过 3 秒钟；

The soldering time must not exceed 3 seconds;

焊锡次数不能超过 5 次，待极片冷却后才能进行下一次焊锡；

The number of solders can not exceed 5 times, and the next solder can not be performed until the electrode is cooled;

严禁直接加热电池，高于 100°C 会损害电池。

It is strictly forbidden to directly heat the battery, and it will damage the battery above 100 °C.

#### 6.2.5 针对意外事件 For accidents

发生意外时，外壳设计应考虑即使在电池出线漏液时也不会发热。

In the event of an accident, the housing design should take into account that there will be no heat even when the battery outlet leaks.

1) 尽量把保护电路与渗透的电解液隔离开。

As far as possible, the protective circuit is separated from the permeable electrolyte.

2) 在不同的电压情况下避免出现小间距的裸露电路—包括插头的周围。

Avoid exposed circuits with small spacing at different voltages-including around the plug.

3) 锂电池不应该有来自电解液的液体，但是一旦发生电解液渗透触及裸露电路，高电势端接子材料可能会溶解然后沉淀到低电势端接子，可能会造成短路。保护板的设计须含有覆盖保护层。

Lithium batteries should not have liquids from electrolytes, but once electrolytic penetration occurs and the exposed circuit is touched, the high-potential end connector material may dissolve and precipitate to the low-potential end connector, which may cause a short circuit. The protection plate shall be designed to contain a cover cover.

### 6.3 其它 other

#### 6.3.1 电池连接 Battery connection

1) 严禁直接焊接引线或设备到电池上。

No direct welding of leads or equipment to the battery is permitted.

2) 极片在焊接引线之前应该先点焊到电池上，直接与电池热焊接，产生的热量会使电池的隔离体及绝缘体受损。

The electrode should be soldered to the battery before welding the lead wire, and it should be soldered directly to the battery.

The heat generated will damage the isolation and insulator of the battery.

#### 6.3.2 电池内部的短路预防 Short circuit prevention in batteries

在电池和引线之间应该有足够的绝缘层用于安全保护。电池的包装构成应没有导致起烟起火的短路情况。

There should be enough insulation between the battery and lead for safety protection. The packaging of the battery shall not cause a short circuit that causes the smoke to catch fire.

#### 6.3.3 禁止拆卸 Demolition prohibited

1) 不要拆卸电池。Do not disassemble the battery.

拆卸电池会发生电池内部短路，会引起起火、爆炸、有害气体或其它问题。

Removing the battery will cause a short circuit inside the battery, which will cause fire, explosion, harmful gas or other problems.

2) 电解液是有害的。Electrolytes are harmful.

#### 6.3.4 不要把电池倾倒在火中。Don't dump the battery in the fire.

不要把电池浸泡在液体当中，像清水、海水及非酒精饮料、果汁、咖啡或其它的饮料中。

Do not soak batteries in liquids, such as water, seawater and non-alcoholic beverages, juices, coffee or other beverages.



### 6.3.5 更换电池。Replacement of batteries.

更换电池应由电池生产商或设备供应商完成，用户不用自行更换。

Battery replacement should be done by the battery manufacturer or equipment supplier, users do not have to replace themselves.

### 6.3.6 禁止使用损坏的电池。Do not use damaged batteries.

电池可能在出货途中碰撞而受损。如果发现电池有异常，例如包装损坏、包装包裹变形，有电解液的味道、发现漏液等等，不要在使用这些电池；如果有电解液的味道或出现漏液，电池放置应该远离火源避免起火爆炸。

Batteries may crash and be damaged during shipment. If the battery is found to be abnormal, such as damage to the package deformation of the package, smell of electrolyte, leakage of liquid, etc..Do not use these batteries; If there is an electrolyte taste or leakage, the battery should be placed away from the source of fire to avoid fire explosion.

### 6.3.7 其它的化学反应。Other chemical reactions.

由于电池是利用化学反应的原理，所以随时间的增加电池的性能会降低，即使是存放很长一段时间而不使用。如果使用条件下充电、放电及周围环境温度等情形不在指定的使用范围内，会缩短电池的使用寿命，或者会产生漏液导致设备损坏。如果电池长时间不能充电，即使充电方法正确，也要更换电池了。

Since the battery uses the principle of chemical reaction, the performance of the battery will be reduced over time, even if it is stored for a long period of time without use. If charging, discharging, and ambient temperature are not within the specified range of usage conditions, the service life of the battery will be shortened, or leakage will result in damage to the equipment. If the battery can not be charged for a long time, even if the charging method is correct, the battery must be replaced.

## 7. 激活 Activation

### 7.1 电池每隔 6 个月检测一次电压，如电压低于 3.5V，需进行电池标准激活。

Please check cell voltage every 6 months. If the voltage is lower than 3.5V, it is necessary to activate the cell.

### 7.2 电池存储 12 个月需进行电池标准激活。

The cell needs to be activated after 12 months;

标准的激活方式为：使用标准充电方式 5.1.1 充电后静置 10 分钟，再使用标准放电方式 5.1.2 放电后静置 30 分钟，使用 600mA 电流恒流充电 0.5 小时。如电池已被装配或已使用，须用配套的充电器和机器做激活。

Cell shall be charged per 5.1.1, rest 10mins, then be discharged per 5.1.2, rest 30mins. Charge the cell at constant current of 600mA for 0.5hours. If the battery has been assembled or used, use the suitable matched charger and machines to activate.

## 8. 包装 Package

电池在包装时需处于半充满状态，包装箱外应标明产品名称、型号、标称电压、数量、出厂日期及相应等级的内阻、容量。

Batteries need to be in a semi-full state during packaging. The product name, model, nominal voltage, quantity, factory date, and corresponding grade of internal resistance and capacity should be indicated outside the package.

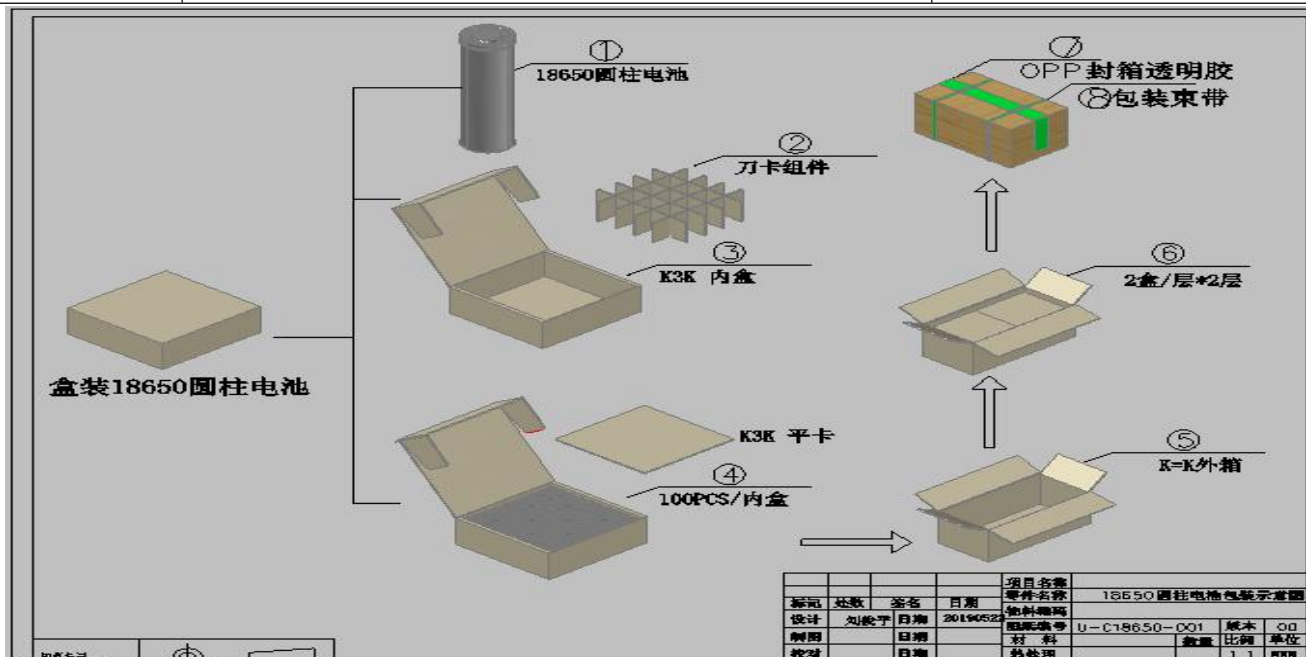

## 9. 保质期 Warranty period

电池的保质期从出厂日期（喷码）开始起 1 年。如果证明电池的缺陷是在制造过程中形成的而不是由于用户滥用及错误使用造成，优特利公司负责退换电池。

The shelf life of the battery begins 1 year from the factory date(spray code). If it is proved that the defect of the battery was formed during the manufacturing process and not caused by the misuse and misuse of the user, Utri is responsible for replacing the battery.

## 10. 电池的存放 Storage of batteries

电池应当在温室下存放，应充到 30%至 50%的电量。如长时间储存，建议每半年充一次电，以防止电池过放电。

Batteries should be stored in greenhouses and should be charged to 30 to 50 per cent of the charge. If stored for a long time, it is recommended to charge the battery every six months to prevent over discharge.

## 11. 产品责任 Product liability

本公司对没有按本规格书规定操作而导致的意外不负责任。

The Company shall not be liable for any accident caused by its failure to comply with these specifications.

## 12. 联系方式 Contact

厂址: 江西省吉安市井冈山经济技术开发区

Site: Jinggangshan Economic and Technological Development Zone, Ji'an City, Jiangxi Province

Tel(电话): 0796-8404221 Fax(传真): 0796-8404211

Tel(Tel): 0796-8404221 Fax(Fax): 0796-8404211

## 13. 注释 annotation

本说明书包括事项应由双方协议确定。

The contents of this specification shall be determined by mutual agreement.