



PRODUCT SPECIFICATION

DOC NO.: PS-1376074-CA

REV. : A

SHEET : 1 OF 14

Specification Approval Sheet

产 品 规 格 书

Customer Name 客户名称 _____
Cell Model 电芯型号 1376074
Cell Capacity 电芯容量 10000 mAh
Customer Model 客户型号 _____
Cell P/N 电芯料号 _____

Prepared by制作	Checked by审核	Approved by批准
李海	刘日日	李光胤
2023-10-29	2023-10-29	2023-10-29

Customer Approved 客户承认 (Stamp) (盖章)	Approved by 批准	Date 日期

Ganzhou Novel Battery Technology Co.,Ltd
规格书有效期: 1年



PRODUCT SPECIFICATION

DOC NO.: PS-1376074-CA

REV. : A

SHEET : 3 OF 14

Index 目录

Index 目录.....	3
1. Scope 使用范围.....	4
2. Model 型号.....	4
3. Reference standard 参考标准	4
4. Specification 产品参数.....	4
5. Cell Drawing 电芯外形尺寸示意图.....	5
6. Cell Performance Criteria 电芯性能检查及测试.....	6
6.1 Visual inspection 外观检查	6
6.2 Standard environmental test condition 标准测试环境	6
6.3 Electrical characteristics 充放电性能	6
6.4 Mechanical and Environmental Test 环境适应性	7
6.5 Safety 安全性能	8
7. Safety Instructions 安全使用说明.....	9
8. Handling of Cells 电池操作注意事项.....	12
9. Notice for Designing Battery Pack 电池外壳设计注意事项.....	13
10. Guarantee Period of Quality 保质期.....	14
11. Others 其它事项.....	14



PRODUCT SPECIFICATION

DOC NO.: PS-1376074-CA

REV. : A

SHEET : 4 OF 14

1. Scope 使用范围

This document describes the Product Specification of the Lithium-ion Polymer (LIP) rechargeable battery cell supplied by GanZhou Novel Battery Technology Co., Ltd.

本规格书适用于赣州诺威新能源有限公司生产的可充电聚合物锂离子电芯的产品性能指标。

2. Model 型号

1376074

3. Reference standard 参考标准

GB31241-2022

4. Specification 产品参数

NO.	Items 项目	Specifications 规格		
1	Nominal voltage 标称电压	3.85V		
2	Charge cut-off voltage 充电限制电压	4.4V		
3	Discharge cut-off voltage 放电终止电压	3.0V		
4	Minimal capacity 最小容量	9800mAh@0.2C discharge		
5	Typical capacity 典型容量	10000mAh@0.2C discharge		
6	Rated energy 额定能量	37.73Wh		
7	Standard charge method 标准充电	Charging the cell initially with constant current at 0.2C and then with constant voltage at 4.4V till charge current declines to 0.02C. 先以0.2C恒流充电，当电芯电压达到4.4V后，改为恒压充电直到充电电流小于或等于0.02C。		
8	Max charge rate 最大充电倍率	1.0C		
9	Max discharge rate 最大放电倍率	1.0C		
10	Operating temperature 工作温度	Charge temperature 充电温度	0~15°C, Max 0.2C cut-off voltage 4.3V	
		Discharge temperature 放电温度	15~45°C, Max 1.0C cut-off voltage 4.4V	
11	Initial Impedance 初始内阻	≤60mΩ		
12	Cell Voltage of shipment 出货电压	≥3.8V		
13	外形尺寸	T	13.70mm Max	Thickness 厚度(不含胶纸)
		W	60.2mm Max	Width 宽度(单折边)
		L	74.7mm Max	Length(Without sealant) 电芯长度(不含极耳胶)
		E	3.0±0.5mm	Top sealing length 顶边宽度
		A	33.0±2.0mm	Tab distance 极耳中心距
		B	5.0±0.2mm	Tab width 极耳宽度
		D	10.0±2.0mm	裁极耳尺寸(含极耳胶)
C	0.2~2.0mm	Sealant Length 极耳胶尺寸		
14	Storage temperature 储存温度	3 months 三个月内	-20°C ~+45°C	The capacity for a long time storage shall be 40~80% range
		6 months 六个月内	23°C±2°C	
		Humidity 湿度	60%±20%	长期存储容量为40%~80%



PRODUCT SPECIFICATION

DOC NO.: PS-1376074-CA

REV. : A

SHEET : 5 OF 14

5. Cell Drawing 电芯外形尺寸示意图

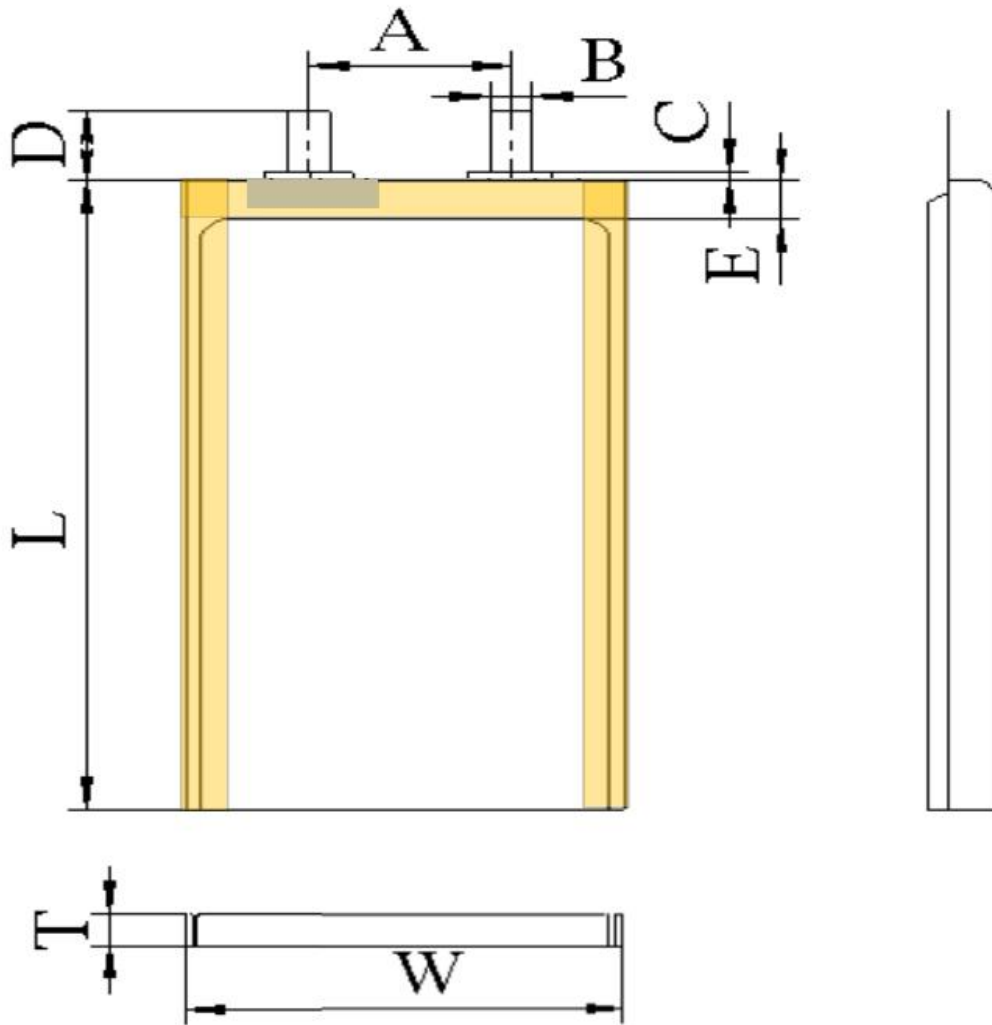

正面喷码

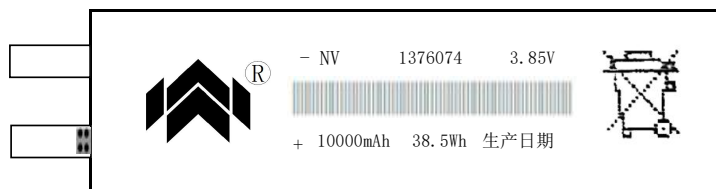



PRODUCT SPECIFICATION

DOC NO.: PS-1376074-CA

REV. : A

SHEET : 6 OF 14

6. Cell Performance Criteria 电芯性能检查及测试

6.1 Visual inspection 外观检查

There shall be no such defect as scratch, flaw, crack, and leakage, which may adversely affect Commercial value of the cell.

不允许有影响电芯价值的外观缺陷,例如:裂纹、裂缝、泄漏等。

6.2 Standard environmental test condition 标准测试环境

Unless otherwise specified, all tests stated in this Product Specification are conducted at below condition:

除非有其他特殊说明,本规格书中所有测试都在以下环境条件进行:

Temperature 温度 : $25^{\circ}\text{C} \sim 30^{\circ}\text{C}$, Humidity 相对湿度: $60 \pm 20\%$

6.3 Electrical characteristics 充放电性能

NO.	Items 项目	Test Method and Condition 测试方法	Criteria 标准
1	Charge/Discharge Cycle 充放电循环	The capacity on 0.2C discharge shall be measured after 300 cycles Of 0.2C charge and discharge at $25 \pm 2^{\circ}\text{C}$. $25 \pm 2^{\circ}\text{C}$ 条件下0.2C充放电循环300次。	Capacity $\geq 80\%$ 容量 $\geq 80\%$
2	Retention Capability 荷电保持能力	After full charging, storing the battery 28 days with $20 \pm 5^{\circ}\text{C}$ condition, and then staying 1 hours with discharge current of 0.2C till 3.0V cut-off voltage. 电芯满充电后,在 $20 \pm 5^{\circ}\text{C}$ 的环境条件下存放28天,然后以0.2C电流连续放电至3.0V终止电压。	Capacity $\geq 85\%$ 容量 $\geq 85\%$

※ Typical capacity 典型容量

The capacity means the average discharge capacity of the cell, which is measured with discharge current of 0.2C with 3.0V cut-off voltage after the standard charge at $25^{\circ}\text{C} \sim 30^{\circ}\text{C}$ environment temperature, unit: mAh
典型容量指 $25^{\circ}\text{C} \sim 30^{\circ}\text{C}$ 温度下,以0.2C电流放电至终止电压时所放出容量对应的容量分布中心值,单位为mAh。

※ Charge/Discharge current rate 充放电电流倍率

Charge/Discharge current rate: $AC(\text{Ah}) = A * \text{Minimal capacity (mAh)}$, for example, $0.02\text{C} = 0.02 * \text{Minimal capacity}$

充放电电流倍率: $AC(\text{Ah}) = A * \text{最小容量 (mAh)}$, 例如, $0.02\text{C} = 0.02 * \text{最小容量}$



PRODUCT SPECIFICATION

DOC NO.: PS-1376074-CA

REV. : A

SHEET : 7 OF 14

6.4 Mechanical and Environmental Test 环境适应性

No.	Items 项目	Test Method and Condition测试方法	Criteria标准
1	Depression 低气压	After the battery is fully charged, the battery is placed in a vacuum box at $20^{\circ}\text{C} \pm 5^{\circ}\text{C}$, and the vacuum reduces the pressure in the box to 11.6kPa and holds it for 6 hours 电池充满电后, 将电池放置于 $20^{\circ}\text{C} \pm 5^{\circ}\text{C}$ 的真空箱中, 抽真空将箱内压强降低至11.6kPa, 并保持6小时	No leak, no smoke, no fire no explosion 无漏液、起火或爆炸
2	Temperature cycling 温度循环	After the battery is fully charged, put the fully charged battery in a constant temperature and humidity box and carry out the following steps: a. increase the temperature of the test chamber to $72^{\circ}\text{C} \pm 2^{\circ}\text{C}$, and hold it for 6h; b. Reduce the temperature of the test chamber to $-40^{\circ}\text{C} \pm 2^{\circ}\text{C}$ and keep it for 6h; Repeat step a)~b), a total of 10 cycles; Store at least 6 h at room temperature $20^{\circ}\text{C} \pm 5^{\circ}\text{C}$ 电池充满电后, 将充满电的电池放在恒温恒湿箱中, 进行以下步骤: a.将试验箱温度升高为 $72^{\circ}\text{C} \pm 2^{\circ}\text{C}$, 并保持6h; b.将试验箱温度降为 $-40^{\circ}\text{C} \pm 2^{\circ}\text{C}$, 并保持6h; 重复步骤 a)~b), 共循环10次; 在室温 $20^{\circ}\text{C} \pm 5^{\circ}\text{C}$ 下至少保存6h	No leak, no smoke, no fire no explosion 无漏液、起火或爆炸
3	Vibration 振动	After standard charge, the battery is to be tested as following conditions: Amplitude: 0.8mm; Frequency: 7~200Hz Direction: X/Y/Z axis for 180min. The battery is to be tested in three mutually perpendicular to each axis. (Reference standard: GB31214-2022) 标准充电后, 对电池施加振幅 0.8mm, 频率范围 7~200Hz 的简谐振动, X/Y/Z每个方向振动时间180min。(具体测试方法按GB31214-2022)	No leak, no smoke, no fire no explosion 无漏液、起火或爆炸
4	Acceleration shock 加速度冲击	After the battery is fully charged, the battery is fixed on the impact stage and a half-sinusoidal pulse impact experiment is performed, in the first 3ms, the minimum average acceleration is $75g_n$, the peak acceleration is $150g_n \pm 25g_n$, the pulse duration is $6\text{ms} \pm 1\text{ms}$, and three acceleration impact experiments are performed in each direction. 电池充满点后, 将电池固定在冲击台上, 进行半正弦脉冲冲击实验, 在最初的3ms内, 最小平均加速度为 $75g_n$, 峰值加速度为 $150g_n \pm 25g_n$, 脉冲持续时间 $6\text{ms} \pm 1\text{ms}$, 每个方向进行三次加速度冲击实验。	No leak, no smoke, no fire no explosion 无漏液、起火或爆炸



PRODUCT SPECIFICATION

DOC NO.: PS-1376074-CA

REV. : A

SHEET : 8 OF 14

No.	Items 项目	Test Method and Condition测试方法	Criteria标准
5	Drop 跌落	After standard charging, the cell is to be dropped from a height of 1 meter onto concrete board, dropped once in the positive and negative directions of three mutually perpendicular X, Y, Z axes. 满充电电芯从1米高处自由跌落到水泥地板上，从X, Y, Z正负方向每个方向自由跌落一次。	No smoke, no fire no explosion 不起火、不爆炸
6	Extrusion 挤压	After the battery is fully charged, the battery is placed in two planes, squeezed perpendicular to the direction of the plate, and an extrusion force of $13.0\text{kN} \pm 0.78\text{kN}$ is applied between the two plates, and the speed of the squeeze battery is 0.1mm/s . The battery should be protected from external short circuits during the test. (Reference standard: GB31214-2022) 电池充满电后，将电池置于两个平面内，垂直于极板方向进行挤压，两平板间施加 $13.0\text{kN} \pm 0.78\text{kN}$ 的挤压力，挤压电池速度为 0.1mm/s 。当压力达到最大值或电池的电压下降三分之一时即可停止挤压实验。试验时电池应防止外短路。（具体测试方法按GB31214-2022）	No fire, no explosion 不起火、不爆炸
7	Heating 热冲击	After the battery is fully charged, it is placed in a hot box, and the temperature is raised to $130^\circ\text{C} \pm 2^\circ\text{C}$ at a rate of $(5 \pm 2^\circ\text{C})/\text{min}$ and kept warm for 30min. 将电池满充电后，放置于热箱中，温度以 $(5 \pm 2^\circ\text{C})/\text{min}$ 的速率升至 $130^\circ\text{C} \pm 2^\circ\text{C}$ 并保温30min。	No fire, no explosion 不起火、不爆炸

6.5 Safety 安全性能

No.	Items 项目	Test Method and Condition测试方法	Criteria标准
1	High temperature external Short-Circuit Test 高温外部短路	After standard charging, place the battery in an environment of $57 \pm 4^\circ\text{C}$, and leave it there for 30 minutes after the surface temperature of the battery reaches $57 \pm 4^\circ\text{C}$. Then use resistance to $80 \pm 20\text{m}\Omega$ wire short circuit it is negative. The test can be terminated when the battery temperature drops to 20% below the peak or the short connection time reaches 24h. 标准充电后，将电池放置 $57 \pm 4^\circ\text{C}$ 的环境中，待电池表面温度达到 $57 \pm 4^\circ\text{C}$ 后，放置30分钟。然后用电阻 $80 \pm 20\text{m}\Omega$ 的导线短路其正负极。当电池温度下降到比峰值低20%，或短接时间达到24h时即可终止试验。	No fire, no explosion 不起火、不爆炸



PRODUCT SPECIFICATION

DOC NO.: PS-1376074-CA

REV. : A

SHEET : 9 OF 14

No.	Items 项目	Test Method and Condition 测试方法	Criteria 标准								
2	Overcharge 过充	<p>After the standard discharge, charge the test voltage with the specified maximum current constant (as shown in the table below), then charge it with the changed voltage constant voltage, stop when the battery is continuously charged for 7 hours or when the battery temperature drops to 20% below peak.</p> <p>标准放电后, 先用规定的最大电流恒流充至试验电压(如下表), 然后以改电压值恒压充电, 当电池持续充电达到7小时或由电池温度下降到比峰值低20%时停止。</p> <table border="1" style="margin-left: auto; margin-right: auto;"> <thead> <tr> <th>充电限制电压(U_a)</th> <th>过充电试验电压(U_c)</th> </tr> </thead> <tbody> <tr> <td>$U_a < 4.25$</td> <td>$U_a + 0.4$</td> </tr> <tr> <td>$4.25 \leq U_a < 4.45$</td> <td>4.65</td> </tr> <tr> <td>$U_a \geq 4.45$</td> <td>$U_a + 0.2$</td> </tr> </tbody> </table> <p style="text-align: right; font-size: small;">单位为伏特</p>	充电限制电压(U_a)	过充电试验电压(U_c)	$U_a < 4.25$	$U_a + 0.4$	$4.25 \leq U_a < 4.45$	4.65	$U_a \geq 4.45$	$U_a + 0.2$	No fire, no explosion 不起火、不爆炸
充电限制电压(U_a)	过充电试验电压(U_c)										
$U_a < 4.25$	$U_a + 0.4$										
$4.25 \leq U_a < 4.45$	4.65										
$U_a \geq 4.45$	$U_a + 0.2$										
3	Forced discharge 强制放电	<p>Discharge the cells to cut off voltage with current of 0.2C at room temperature; What happens when the discharge is over, reverse charge with 1 C current for 90 minutes; After test, check the impedance, voltage, thickness, appearance of cells or batteries.</p> <p>室温下用0.2C的电流将电芯或电池放电至终止电压; 放电结束后, 以1C电流反向充电90分钟; 测试后, 检查电芯或电池的内阻、电压、厚度、外观。</p>	no fire, no explosion 无起火、不爆炸								

7 Safety Instructions 安全使用说明

The cell contains flammable materials such as organic solvents. Mishandling the cell may cause fire, smoke, or an explosion and the cell's functionality will be seriously damaged. Protection circuitry must be designed into the application device to protect the cell. Additionally, novel recommends adding these instructions to the owner's manual. Please read and check the following prohibited actions.

电芯含有有机溶剂等易燃材料。对电芯不正确的操作可能导致起火、冒烟、爆炸, 或电芯功能的严重破坏。应用装置中必须设计保护电路保护电芯。诺威特别建议如下使用说明给电芯使用者, 请仔细阅读与核实如下注意事项。

7.1 Protection Function 保护功能

The cell shall be with the overcharge protection, over-discharge protection, and over-current protection during using. Protective circuit must have protective functions as follows:

电池必须在有过充、过放、过流保护的条件下使用, 保护电路必须具有以下保护功能:

(1) Overcharge protection 过充电保护

Overcharge protection stops charging if any cell of the battery pack reaches 4.45V

过充保护电路防止电池中任何电芯电压超过4.45V

(2) Over-discharge protection 过放电保护

The Over-discharge protection monitors the voltage of any cell in the pack and works to avoid a drop in the cell voltage to 2.75V or less.

过放保护电路防止电池中任何电芯电压低于 2.75V。

(3) Over-current protection 过流保护

The cell shall be discharged at less than the maximum discharge current specified in the Specification Approval Sheet. A high discharge current may reduce the discharge capacity observably or cause overheating.

电池放电电流不可高于规格书中指定的最大电流。高于规格书的大电流放电将导致电池容量降低或电池过热。

(4) Cell potential swelling range: 以下使用可能导致电芯鼓包:

① Cell over discharge mode: Voltage 2.0V or lower.

电池过放状况: 电压 2.0V 或更低。

② High temperature ($\geq 60^\circ\text{C}$) storage: Voltage 4.1V or higher for longer period storage.

高温 ($\geq 60^\circ\text{C}$) 存储: 电压 $\geq 4.1\text{V}$ 长时间存储。



PRODUCT SPECIFICATION

DOC NO.: PS-1376074-CA

REV. : A

SHEET : 10 OF 14

③Floating charging with the trickle current.

电池持续以涓流充电（浮充）。

7.2 Danger 危险

◇ Do not immerse the battery in liquid such as water, beverages, or other fluids.

禁止将电池浸入如水、饮料或其它液体中。

◇ Do not use or place the battery near an fire, heater or high temperature environment (above 80°C).

禁止在靠近火、加热器或高温(>80°C)环境中使用或搁置电池。

◇ Do not use unauthorized chargers.

禁止使用未经授权的充电器。

◇ Do not attach or insert battery with polarity reversed.

禁止将电池极性反转连接。

◇ Do not connect the battery to an AC outlet or DC automotive plug.

禁止将电池连接到 AC 插座或 DC 的汽车充电插座。

◇ Do not use the battery in equipment for which it was not intended.

禁止将电池使用在其它装置或设备中。

◇ Do not incineration the battery in fire or heat it.

禁止焚烧电池或对其进行加热。

◇ Do not short-circuit the battery by directly connecting the positive and negative terminal with metal object such as wire.

禁止使用导线等金属物体直接连接电池正负极短路电池。

◇ Do not excessive impact to the battery such as striking, throwing, trampling, etc.

禁止撞击、抛掷、践踏等对电池的过度机械冲击。

◇ Do not penetrate the battery with a nail or other sharp object.

禁止使用钉子或其它尖锐物体刺穿电池。

◇ Do not disassemble the battery.

禁止拆解电池。

◇ Do not charge the battery at high temperature (>55°C) or discharge it at high temperature (>60°C).

禁止在高温下对电池充电(>55°C)、和放电(>60°C)。

7.3 Warning 警告

◇ Keep the battery away from small children. If the battery or any of its component parts is swallowed, seek medical attention immediately.

将电池放在小孩够不到的地方。如果电池或者电池任意部件被小孩吞食，必需立刻就医。

◇ Do not place the battery in or near a microwave or other cooking appliances. If subjected to heat or strong electromagnetic radiation, the battery may leak, generate heat, smoke, catch fire, or explode.

禁止将电池放在靠近微波设备或其它烹饪装置附近，如果电池被加热或受到强电磁辐射，可能发生漏液、发热、冒烟、着火等。

◇ Do not mix with other batteries. The battery should not be used with other batteries having a different capacity, chemistry, or manufacturer. Doing so could cause the battery to generate heat, smoke, catch fire, or explode.

禁止与其它电池混用。因与其它电池有不同的容量、成分、制造工艺等，相互混用可能会发热、冒烟、着火等。



PRODUCT SPECIFICATION

DOC NO.: PS-1376074-CA

REV. : A

SHEET : 11 OF 14

◇ Immediately remove it from the device or charger, and stop using it, if there are noticeable abnormalities, such as smell, heat, discoloration, or deformity. The battery may be defective and could generate heat, smoke, catch fire, or explode with continued use.

如果电池在使用或贮存中有明显异常，如发出异味、发热、变色、变形，或是在充电过程中出现任何异常现象，立即将电池从使用装置或充电器中移开，并停止使用。电池可能有缺陷，继续使用可能导致发热、冒烟、着火等。

◇ Stop charging if the charge process cannot be finished within the specified time.

如果充电不能在规定的时间内完成，停止充电。

◇ Do not use a leaking battery near open flame.

禁止将漏液电池靠近火源。

◇ Do not touch a leaking battery. If liquid leaking from the battery gets into your eyes, immediately flush your eyes with clean water and seek medical attention. If left untreated, it will cause significant eye damage.

禁止触摸漏液电池。如果电解液不小心进入眼睛，请不要揉擦，应马上用清水冲洗眼睛，并立即送医院治疗，否则会伤害眼睛。

◇ To prevent short-circuit or damage during transport or store, securely pack the battery in a case or carton.

Do not transport and store the battery together with metal objects such as necklaces, hairpins, etc.

防止在运输和存放过程中短路或损坏电池，必需将电池安全包装在盒子或纸箱中。不要与金属物体如项链、发夹等一起运输和存储。

7.4 Caution 注意

◇ Read the manual before use. Keep for future reference.

电池使用前注意阅读使用手册，并保存手册便于以后查阅。

◇ Do not use or leave the battery at very high temperature ($>60^{\circ}\text{C}$, for example, at strong direct sunlight or a vehicle in extremely hot conditions). Otherwise, it can overheat or fire or its performance will be degenerate and its service life will be decreased.

禁止在高温下 ($>60^{\circ}\text{C}$ ，如直射的阳光下或很热的汽车中) 使用或搁置电池，否则可能会引起电池过热、起火或功能失效，或者导致电池寿命减短或损坏电池。

◇ Do not use the battery where static electricity in excess of 1000V is generated as it may damage the protection circuit, and cause hidden trouble of safety

禁止在发电超过 1000V 的静电环境使用电池，否则可能破坏电池保护电路，导致不安全的隐患发生。

◇ Only charge the battery between 0°C and 55°C . Charging outside of this temperature range may cause the battery to leak, generate heat, or result in serious damage. It may also cause the battery's performance and life to deteriorate.

电池只能在 $0^{\circ}\text{C}\sim 55^{\circ}\text{C}$ 温度范围充电。超出此温度范围可能导致电池漏液、发热，或导致电池严重的损坏。它也可能导致电池的性能和寿命的恶化。

◇ Read the charger's manual before use for proper charge method.

在充电前仔细阅读充电器使用说明，使用正确的充电方法。

◇ Please contact the supplier if the battery gives off an unusual odor, generates heat, or shows signs of rust prior to its initial use.

在首次使用前，如果电池发出明显的异味、发热或锈蚀迹象，请联系电池供应商。

◇ Parents must explain how to use the system and the battery. Please check back periodically to ensure children are using the system and the battery correctly.

给小孩使用前大人必须讲解清楚如何使用设备和电池，并定期跟踪确认，以确保小孩正确使用。

◇ Do not charge or discharge near flammable materials. Doing so could result in fire.

请不要靠近易燃材料充放电电池，否则可能产生起火隐患。

◇ If electrolyte leaks from the battery and comes into contact with skin or clothing, immediately flush with water. Otherwise, it may cause skin irritation.

如果电解液从电池漏出并接触到皮肤或衣服，立即用水冲洗，否则导致刺激皮肤。



PRODUCT SPECIFICATION

DOC NO.: PS-1376074-CA

REV. : A

SHEET : 12 OF 14

◇ If the battery pack have a system interface consisting of stripped lead wires or exposed contact plates, handle with due care. Temporarily insulate exposed contacts and conductors with an insulator such as polypropylene tape or polyvinylchloride tape. Failure to do so could result in an electrical shock, a short circuit causing the battery to generate heat, smoke, catch fire, or the combustion of other materials.

如果电池组有一个由剥离导线或暴露的接触板组成的系统接口，应谨慎操作。可暂时用聚丙烯胶带或聚氯乙烯胶带隔离暴露接触导体与绝缘体。不这样做可能会导致触电，短路造成电池发热、冒烟、着火，或其它材料的燃烧。

◇ When disposing of the battery, be aware discharged battery may cause fire, tape the terminals to insulate them. Recycle it according to local rules and regulations.

处理电池时，注意带电的电池可能会造成火灾，应该用胶带将电路端子隔离。根据当地法规回收。

◇ In case the battery terminals are dirt, clean the terminals with a dry cloth before use. Otherwise power failure or charge failure may occur due to the poor connection with the instrument.

如果电池电路端子弄脏，使用前应用干布抹净，否则可能会因接触不良而影响性能失效。

◇ The batteries should be stored at room temperature, charged to about 40% to 60% of capacity. In case of over-discharge, batteries should be charged to 3.90V with standard charge method for one time every 3 months while storing and batteries should be charge-discharged with standard method for one time after being stored more than one year in order to activate it and restore energy.

电池应当在室温下存放，应充电到 40%~60%的电量。为防止电池过放，每 3 个月按标准充电方式进行充电至 3.90V。如储存时间超过一年，建议每年按标准充放电方式进行一次充、放电循环以激活电池。

8 Handling of Cells 电池操作注意事项

(1) Soft aluminum packing foil (铝塑膜软包装)

The soft aluminum packing foil is very easily damaged by sharp edge parts such as Ni-tabs and needles, do not strike battery with any sharp edge parts.

电池外包装铝塑膜易被镍片、尖针等尖锐部件损伤，禁止用尖锐部件碰伤电池。

◇ Do not strike cell with any sharp edge parts 勿用尖锐处撞击电池。

◇ Trim your nail or wear glove before taking cell 剪掉指甲，或者戴手套。

◇ Clean worktable to make sure no any sharp particle 清理工作台，避免尖锐零部件碰伤电池。

(2) Sealed edge may be damaged by heat above 100°C, bend or fold sealed edge.

电池封边被加热到 100°C 以上以及弯折封边都容易使封边受损。

(3) Prohibition short circuit (禁止电池短路)

◇ Never make short circuit cell. It generates very high current which causes heating of the cells, and may cause electrolyte leakage, gassing or explosion that is very dangerous.

避免电池短路。短路会产生很大的电流而使电池发热以及电解液泄漏，产生有毒气体或燃烧，是非常危险的。

◇ The rechargeable Li-polymer cell tabs may be easily short-circuited by putting them on conductive surface. Such outer short circuit may lead to heat generation and damage of the cell. An appropriate circuitry with PCM shall be employed to protect accidental short circuit of the battery pack.

电芯正负极耳连接在导电物体表面很容易短路，外部短路会导致发热及损害电池。选用一个合适的保护电路可以在意外短路时保护电池。

(4) Mechanical shock (机械撞击)

◇ The rechargeable Li-polymer cells have less mechanical endurance than metal-can-cased lithium ion cell..

可充锂聚合物电池比金属壳方形电池的机械耐久性更小。

(5) Pre-charge Function (预充电)

◇ The system shall not initiate normal charging if the battery voltage is below the over-discharge protection voltage defined in the Specifications. In this case, the system may support a pre-charging function to bring the battery voltage above the required threshold. The recommended pre-charge procedure is as below: The Cell battery pack charging shall start with a low current ($\leq 0.03C_{min}$ mA) for approximately 30 minutes before rapid charging starts. The normal charging shall be started after the (individual) Cell voltage has been reached above 3V within approximately 30 minutes that can be determined with the use of an appropriate timer for pre-charging. In case the (individual) Cell voltage does not rise to 3V within the pre-charging time, then the charger shall have functions to stop further charging and display that the Cell/pack is at abnormal state.



PRODUCT SPECIFICATION

DOC NO.: PS-1376074-CA

REV. : A

SHEET : 13 OF 14

如果蓄电池电压低于本规范中规定的过放电保护电压，则系统不得启动正常充电。在这种情况下，系统可以支持预充电功能，使电池电压高于所需的阈值。建议的预充电程序如下：电池组应以低电流（ $\leq 0.03C_{min}$ mA）开始充电约30分钟，然后才开始正常充电。正常充电应在大约30分钟内达到（单独）电池电压超过3V后开始，可以使用适当的预充电计时器进行确定。如果（个别）电池电压在预充电时间内未上升到3V，则充电器应能停止进一步充电，并显示电池/电池组处于异常状态。

◇ The actions such as Falling, hitting, bending may cause degradation of rechargeable Li-polymer cell characteristics.

跌落、碰撞、弯曲等等都可能会降低聚合物电池的性能。

(6) Handling of Tabs（极耳操作注意事项）

The cell tabs are not so stubborn especially for aluminium tab. Do not bend tabs unnecessarily.

极耳的机械强度并非异常坚固，特别是铝极耳。没有必要时禁止弯折极片。

(7) Check the Voltage and resistance before Operating the cell（电芯pack上线时需检测电压、内阻）

After long-distance transportation or long-term storage of batteries, voltage and resistance testing is required before Operating the cell.

电芯长途运输或长期储存后，电芯pack上线时需检测电压、内阻。

9 Notice for Designing Battery Pack 电池外壳设计注意事项

(1) Pack Toughness（外壳坚韧度）

Battery pack should have sufficient strength and the rechargeable Li-polymer cell inside should be protected from mechanical shocks.

电池外壳应该有足够的机械强度，避免聚合物电池受机械撞击。

(2) Cell Fixing（电池的固定）

The rechargeable Li-polymer cell should be fixed to the battery pack by its large surface area.

No cell movement in the battery pack should be allowed.

电池最大面积的一面应该固定在外壳上，安装后电池不能有松动。

(3) Inside Design（外壳内部设计）

No sharp edge components should be insides the pack containing the rechargeable Li-polymer cell.

外壳内安装电池的部位不应有锋锐边。

(4) To prevent the cell short circuit avoiding the cell's tabs, components of the PCM and some electrically conductive components to contact the aluminium layer edge of the cell pouch.

避免电池的正负极耳或其它导电物质接触电芯铝塑膜包装切口边缘。

(5) Tab Connection（极耳连接）

Laser welding or ultrasonic welding or spot welding is recommended for rechargeable Li-polymer cell tab connection method.

Battery pack should be designed that shear force are not applied to the rechargeable Li-polymer cell tabs.

If apply manual solder method to connect tab with PCM, below notice is very important to ensure cell performance:

建议使用激光焊、超声波或点焊焊接方法；外壳设计应使极耳不受外力。

如果使用人工焊接保护板，下面的注意事项对于确保电池性能非常重要：

◇ The solder iron should be temperature controlled and ESD safe;

焊接烙铁的温度必须可控且可防静电；

◇ Soldering temperature should not exceed 370°C;

焊接时烙铁的温度不能超过 370°C；

◇ Soldering time should not be longer than 3s;

焊锡时间不能超过 3 秒钟；

◇ Re-soldering times should not exceed 5 times, Keep cell tab cold down before next time soldering;

焊锡次数不能超过 5 次，待极片冷却后才能进行下一次焊锡；



PRODUCT SPECIFICATION

DOC NO.: PS-1376074-CA

REV. : A

SHEET : 14 OF 14

◇ Directly heat cell body is strictly prohibited, cell may be damaged by heat above 60°C.

严禁直接加热电芯，高于 60°C 会损害电芯。

10 Guarantee Period of Quality 保质期

Guarantee period of quality is one year from the date of shipment. Novel guarantees to give a replacement in case of cell with defects proven due to manufacturing process instead of the customer's abuse.

电池的保质期从出货之日算起为一年。如果证明电池的缺陷是在我们公司制造过程中造成的而不是客户错误使用造成，本公司负责退换电池。

11 Others 其它事项

(1) The customer is requested to contact Novel in advance, if the customer needs other applications or operating conditions out of those described in this document. Additional experimentation may be required to verify performance and safety under such conditions.

客户若需要将电池用于超出文件规定以外的设备，或在文件规定以外的使用条件下使用电池，应事先联系诺威公司，因为需要进行特定的实验测试以验证电池在该使用条件下的性能及安全性。

(2) Novel will take no responsibility for any accident when the cell is used under other conditions than those described in this Document.

对于在超出文件规定以外的条件下使用电池而造成的任何意外事故，诺威公司概不负责。

(3) Novel will inform the customer in a written form regarding proper use and handing of the cell, if it is necessary.

如有必要，诺威公司会以书面形式告之客户有关正确操作使用电池的改进措施。

(4) Any matters that this specification does not cover should be conferred between the customer and Novel.

任何本说明书中未提及的事项，须经双方协商确定。

Customer Inquiry 客户要求

Model: 1376074

型号: 1376074

Version: B

版本: B

1. IF clientele ratify specification and showpiece, please sign back specification to Novel in 1 week, or else blank out it.

如果客户认可规格书和样品，请于7天内回签规格书给诺威公司，过期视为作废。

2. The customer is requested to write down your information and contact Novel in advance, if and when the customer needs applications or operating conditions other than those described in this document. Novel could design and build such products according to your special request.

如果客户需要其他方面的说明或工作条件与规格书内容不一致，请客户提前和诺威公司联系。